

BIFFI

Compact electric actuator for 90° operation, complete with the intelligent control unit ICON 2000 to fit small valves

Mechanical features

- Light weight and compact design, mounting flange acc. ISO 5211
- Constant torque for complete operating stroke
- Torque control in both rotation directions
- Double spur gear reduction and planetary gear system for a high reduction ratio with inherent self-locking characteristics.
- All gearing with cut teeth, metal made, running in oil for high and constant efficiency and low power consumption
- All rotating parts supported by roller bearings and a permanent oil lubrication
- Manual operation always engaged but not rotating during automatic operations
- Mechanical adjustment of the position by mechanical stops connected directly to the actuator housing
- Anodized aluminium enclosures, protection by epoxy-polyurethane painting

Features ICON 2000

- Easy set-up and commissioning
- Initial tuning without unscrewing a single bolt or nut
- Reduced set-up time
- Double displays
- Position indication in case of power failure
- Local push buttons for full actuator access
- Password protection to avoid unauthorized access
- Diagnostics are displayed in one of the available languages for both alarms and warnings
- Reduced number of parts ensures higher reliability and lower maintenance cost

Environment protection

• Only waterproof

IP 68 according to IEC 529 and CEI EN60529 (15m dept/90 hours), or alternatively NEMA 4, NEMA 4X and NEMA 6 according to NEMA ICS6.

• Standard explosionproof degree

Eex-d IIB T4 according to EN50014, EN50018 and EN50281-1-1 Class I, div. 1 group C and D – Class II, III, div. 1 groups E, F and G.

IP 68 according to IEC 529 and CEI EN60529 (15m dept/90 hours), or alternatively NEMA 4, NEMA 4X and NEMA 6 according to NEMA ICS6



General application

Suitable for actuation of ball, plug, butterfly valves or dampers.

Heavy duty applications such as oil and gas, petrochemical, power and water industries.

Technical data

Voltages	: 110/220V-1Ph-50Hz 115/240V-1Ph-60Hz 230/400V-3Ph-50Hz 240/415V-3Ph-50Hz 440/480V-3Ph-60Hz
Torques	: up to 600 Nm
Time/90° stroke	: from 6 up to 60 sec.
Temperature	: -30°C to +85°C
	For other temperature ranges please contact Sales office

Control Package Features

- Torque/position end-of-travel limits (1)
- Position display (1)
- Three push buttons (open-stop-close) (1)
- Two bi-coloured LEDs (open/opening; close/closing) (1)
- Selector switch (local-off-remote) (1)
- Remote control via dry contacts (1)
- Reversing contactor (1)
- Control transformer (fused primary and secondary) (1)
- Local selector switch status (1)
- Auto-phase correction (1)
- Single phase protection (1)
- Monitor relay (1)
- Speed control (timer) (1)
- Remote control via 24 volt thru 125 volt AC or DC signal (1)
- Motor running indication (1)
- Alarm bi-coloured LED (1)
- Emergency shutdown (ESD) (1)
- 4-20 mA input and output (2)
- 4-20 mA output (selectable Position or Torque) (2)
- Network options:
 - ProfiBus DP (2)
 - FieldBus foundation (2)
 - LonWorks (2)
 - ModBus (2)
 - DeviceNet (2)
- Non-intrusive torque and position limit settings (1)
- Configuration parameters are set locally or remotely (1)
- High/low internal temperature alarm (2)
- 3 1/2 digits LCD display for Position (1)
- 2 x 16-character lines alphanumeric display for configuration, diagnostics and visualisation (1)
- Auxiliary battery (remote position transmission) (2)
- Jammed valve protection (1)
- Auxiliary heater (2)
- Instantaneous reversal protection (1)
- Programmable torque/position end of travel (1)
- Maximum torque alarm (1)
- Electronic temperature alarm (1)
- Programmable clockwise or counterclockwise valve rotation (1)
- Electronic nameplate (1)
- Data log (storage of main events) (1)
- Alarm diagnostics (1)
- Programmable in five languages (1)

Notes

- (1) Base unit
- (2) Optional module

Test summary

- **Life test**
Standard F01-2000 life test is based on AWWA 540-93 for a minimum of 10,000 cycles.
- **Vibration test**
F01-2000 are certified as per IEC 60068-2-6-Appendix B (plant induced): frequencies from 1 to 500 Hz (in 3 axes) with 2.0g peak acceleration. Sweep cycles in each axis: 10.
- **Seismic test**
F01-2000 are tested in accordance with IEC 60068-2-57: frequencies from 1 to 35 Hz (in 3 axes) with max 2.0g peak acceleration. Verification of structural integrity at 5g. endurance of oscillogram: 30 seconds.
- **Environmental test**
F01-2000 are tested according to the following standards: IEC 68-2-1 (cold) up to -55°C, IEC 68-2-2 (dry heat) up to +85°C, IEC 68-2-3 (damp heat) up to +40°C with 93% relative humidity.
- **Salt spray test**
F01-2000 external coating is tested for resistance to salt spray for 1,500 hours according to ASTM B117/IEC 68-2-11.
- **Noise test**
F01-2000 are tested according to EN 21680. Noise level is less than 65 dB (grade A) at 1m distance.

General Configuration

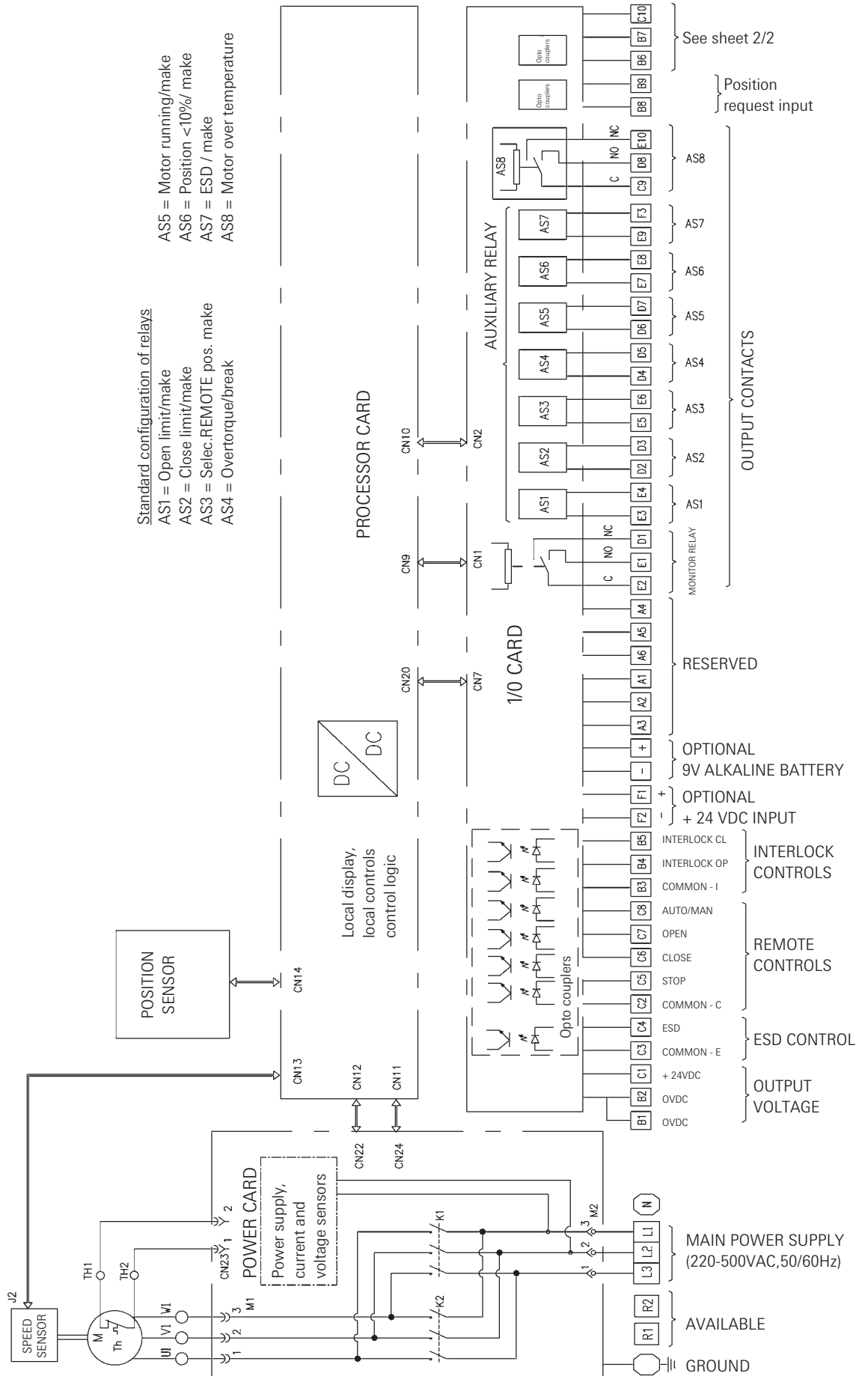

Standard configuration of relays
 AS1 = Open limit/make
 AS2 = Close limit/make
 AS3 = Selec.REMOTE pos. make
 AS4 = Overtorque/break
 AS5 = Motor running/make
 AS6 = Position <10%/ make
 AS7 = ESD / make
 AS8 = Motor over temperature

ACTUATOR

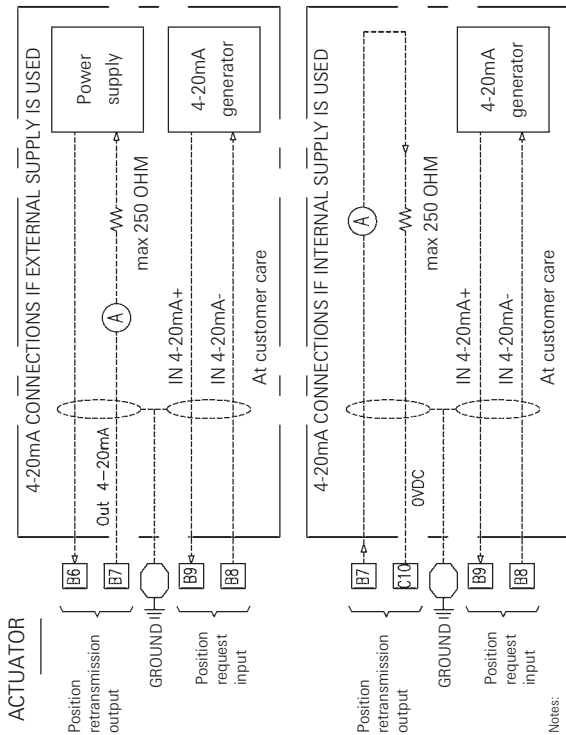

Notes:

- 1) B1/B2 : Internally linked
- 2) C1 : +24 Vdc not regulated, max 4W
- 3) Control signal levels: Minimum "ON" > 20Vdc or 20Vac (50/60Hz)
Maximum "ON" < 125Vdc or 120Vac (50/60Hz)
Maximum "OFF" < 3 Vdc or ac
Minimum signal duration > 300ms
Total current drawn for remote controls < 25mA
- 4) Monitor relay:
Voltage free, change-over contact: max voltage 250Vac or 30Vdc; max current 5A/min; voltage 5Vdc - min. current 10mA
See instruction manual to view or configure the switching conditions of relay
-E2/D1 contact is closed when the configured condition occurs
- 5) AS1, AS2, AS3, AS4, AS5, AS6, AS7: Voltage-free contact. Max voltage 250Vac or 30Vdc; max current 5A / Min voltage 5Vdc - min current 10mA. Contact can be configured to make or break on condition. See instruction manual to view or configure switching conditions of relays.
- 6) AS8: Voltage free, change-over contact: max voltage 250Vac or 30Vdc; max current 5A/min; voltage 5Vdc - min. current 10mA
See instruction manual to view or configure the switching conditions of relay
-C9/D8 contact is closed when the configured condition occurs
- 7) A1, A2, A3 : Internal supply 24Vdc
- 8) B1, B2, B3 : External supply 20-125Vdc or 20-120 Vac (50/60Hz)
- 9) Controls mode:
Option A1/B1 : 4 wires latched (SP configuration = BREAK)
Option A2/B2 : 3 wires push to run
 : 3 wires latched with instant reserve
 : 2 wires open contact opens
 : 2 wires open contact closes
Option A3/B3 : 2 wires open contact closes
- 10) A/M Open: Remote/Auto Actuator control by 4-20mA input signal
A/M Closed: Remote/Man Actuator control by remote push-buttons

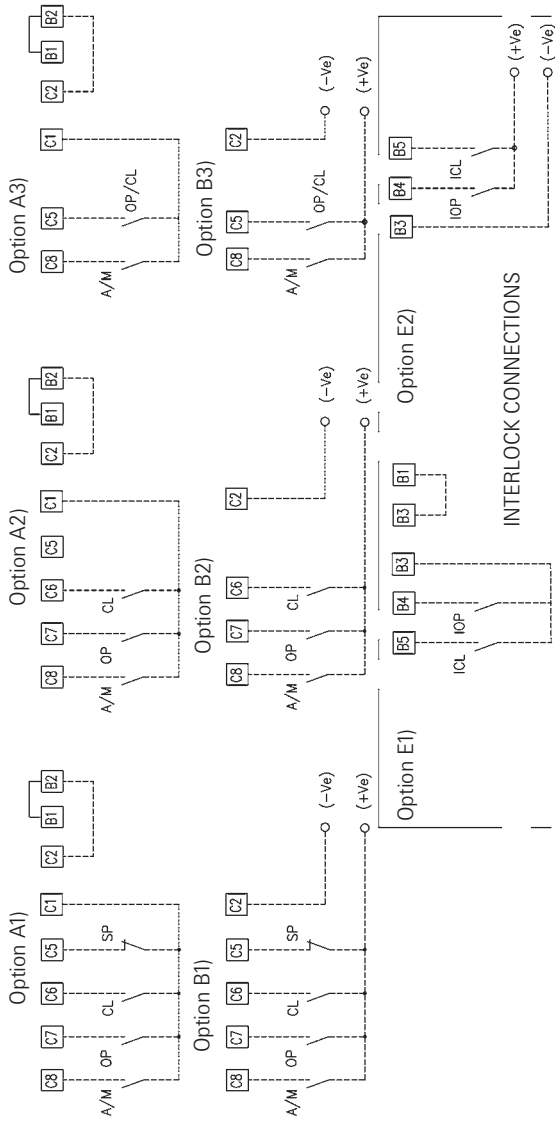

Option E1: Internal supply 24Vdc INTERLOCK active with closed or open contact (to be configured)

Option E2: External supply 20-125 Vdc or 20-120 Vac (50/60Hz) INTERLOCK active with closed or open contact (to be configured)

See Instruction handbook to configure INTERLOCK signal type

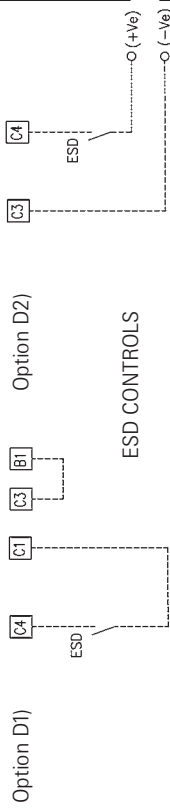

Option D1: Internal supply 24Vdc ESD active with closed or open contact (to be configured)

Option D2: External supply 20-125 Vdc or 20-120 Vac (50/60Hz) ESD active with closed or open contact (to be configured)

See instruction manual to configure ESD signal type, ESD action and priority.

If customers wish to have the thermostat bypassed during ESD operation, it should be noted that any certification for actuator enclosure in hazardous area will be invalidated.

LEGENDA

M	=	Three-phase motor
Th	=	Motor thermostat
OP	=	OPEN control
CL	=	CLOSE control
SP	=	STOP control
K1	=	Opening/Closing contactor
K2	=	Opening/Closing contactor



Performances

Nominal torque (Nm) and time (sec) for 90 degrees of rotation at 50Hz/60Hz Handwheel

Model	6/5	12/10	15/12	30/25	45/37	60/50	torque factor	turns/90°
F01.150-052			150				48x10 ⁻³	21
F01.150-054				150				
F01.150-056					150			
F01.150-058						150		
F01.150-052	150							
F01.150-054		150						
F01.300-052			300					
F01.300-054				300				
F01.300-056					300			
F01.300-058						300		
F01.300-102	300							
F01.300-104		300						
F01.600-102			600					
F01.600-104				600				
F01.600-106					600			
F01.600-108						600		
Ratio	1036:1	1036:1	2759:1	2759:1	2759:1	2759:1		

Notes

1. The above characteristics are referred to the actuators with 3-phase or 1-phase asynchronous motors
2. For modulating duty, please contact Sales office.

Definitions

- Actuator duty according to IEC 34-1: On-Off: S2-30 minutes
Inching: S4-25%, max 200 starts/hour
- Nominal torque = the output torque given by the actuator when the torque device is set and trips at max settable value of its scale
- Stall torque = from 1.4 to 2 times the nominal torque
- Time for 90° rotation = the actuator nominal operating time when the running torque is yielded
- Running torque = 0.4 times the nominal torque
- Hand-wheel torque factor = multiply the required output torque by this factor to obtain the hand-wheel torque
- Bold-faced values represent the performances of Standard models with 3-ph motors
- Identification code: Model/Nominal torque-time at 50 or 60Hz
e.g.: F01.150-052/150-12



Electrical details 3-phase supply

Model	400V-50Hz-3Ph							415V-50Hz-3Ph							480V-60Hz-3Ph						
	KW	RPM	In(A)	Is(A)	Icc(A)	PF	Eff	KW	RPM	In(A)	Is(A)	Icc(A)	PF	Eff	KW	RPM	In(A)	Is(A)	Icc(A)	PF	Eff
F01.150-052	0.040	2820	0.25	0.40	1.00	0.47	0.52	0.040	2820	0.22	0.40	1.00	0.47	0.54	0.048	3380	0.25	0.40	1.00	0.47	0.49
F01.150-054	0.020	1400	0.16	0.20	0.40	0.42	0.46	0.020	1400	0.15	0.20	0.40	0.42	0.44	0.024	1680	0.16	0.20	0.40	0.42	0.43
F01.150-056	0.014	930	0.14	0.20	0.40	0.38	0.40	0.014	930	0.12	0.20	0.40	0.38	0.43	0.017	1120	0.14	0.20	0.40	0.38	0.38
F01.150-058	0.010	700	0.12	0.20	0.50	0.36	0.35	0.010	700	0.10	0.20	0.50	0.36	0.39	0.012	840	0.12	0.20	0.50	0.36	0.34
F01.300-052	0.040	2820	0.25	0.40	1.00	0.47	0.52	0.040	2820	0.22	0.40	1.00	0.47	0.54	0.048	3380	0.25	0.40	1.00	0.47	0.49
F01.300-054	0.020	1400	0.16	0.20	0.40	0.42	0.46	0.020	1400	0.15	0.20	0.40	0.42	0.44	0.024	1680	0.16	0.20	0.40	0.42	0.43
F01.300-056	0.014	930	0.14	0.20	0.40	0.38	0.40	0.014	930	0.12	0.20	0.40	0.38	0.43	0.017	1120	0.14	0.20	0.40	0.38	0.38
F01.300-058	0.010	700	0.12	0.20	0.50	0.36	0.35	0.010	700	0.10	0.20	0.50	0.36	0.39	0.012	840	0.12	0.20	0.50	0.36	0.34
F01.300-102	0.080	2850	0.40	0.50	1.50	0.56	0.54	0.080	2850	0.35	0.50	1.50	0.56	0.57	0.096	3420	0.40	0.50	1.50	0.56	0.52
F01.300-104	0.040	1420	0.30	0.40	1.00	0.42	0.48	0.040	1420	0.30	0.40	1.00	0.42	0.44	0.048	1700	0.30	0.40	1.00	0.42	0.46
F01.600-102	0.080	2850	0.40	0.50	1.50	0.56	0.54	0.080	2850	0.35	0.50	1.50	0.56	0.57	0.096	3420	0.40	0.50	1.50	0.56	0.52
F01.600-104	0.040	1420	0.30	0.40	1.00	0.42	0.48	0.040	1420	0.30	0.40	1.00	0.42	0.44	0.048	1700	0.30	0.40	1.00	0.42	0.46
F01.600-106	0.030	940	0.25	0.40	0.80	0.40	0.46	0.030	940	0.22	0.40	0.80	0.40	0.47	0.036	1130	0.25	0.40	0.80	0.40	0.44
F01.600-108	0.020	720	0.20	0.30	0.60	0.38	0.40	0.020	720	0.20	0.30	0.60	0.38	0.37	0.024	860	0.20	0.30	0.60	0.38	0.38

Definitions

- **KW** = motor nominal power
- **RPM** = motor nominal speed in round per minute
- **In** = nominal current of the motor, according to IEC 34-1, which approximately corresponds to 40% of the actuator nominal torque
- **Is** = current which approximately corresponds to the actuator nominal torque (torque set 100%); we recommend the selection of cables and protections based on the above values
- **Icc** = locked rotor current
- **PF** = power factor
- **Eff** = motor efficiency

Motor insulation class H

Motors duty according to IEC 34-1

For ambient temperature up to +65° C: - S2-30 minutes or S4-25%, max 200 starts/hour

For ambient temperature up to +85° C: - S2-15 minutes or S4-25%, max 60 starts/hour

Tolerances

Nominal Voltage Tolerance: ± 6%

Nominal Frequency Tolerance: ± 2%

Momentary max permissible voltage variation: +10%; -15%

Other tolerances according to IEC 34-1

Notes

The current values shown on the table are referred to motors with Star connection; when the phases are Delta-connected multiply the current figures by factor 1.73



Overall dimensions

Cables entries	a	b	c
NPT #	1"	1" ½	1"
ISO Rc 7/1 •	1"	1" ½	1"
EN 5026 •	M32x1.5	M40x1.5	M32x1.5

Notes

- * = space for cover removal
 - # = standard version
 - = optional version, available on demand
- Not certified drawing: certified dimensions will be supplied on request.
All dimensions are in mm

Notes

1. Insert bush supplied by BIFFI with unmachined bore; larger bores can be supplied with solid piece bush
2. Fixing bolts or rods supplied by BIFFI only on request, minimum material required ISO class 8.8
3. dx= the maximum accepted diameter described by the key
4. Position of the shaft with closed valve
5. Additional ISO PCD is provided as shown in column FL

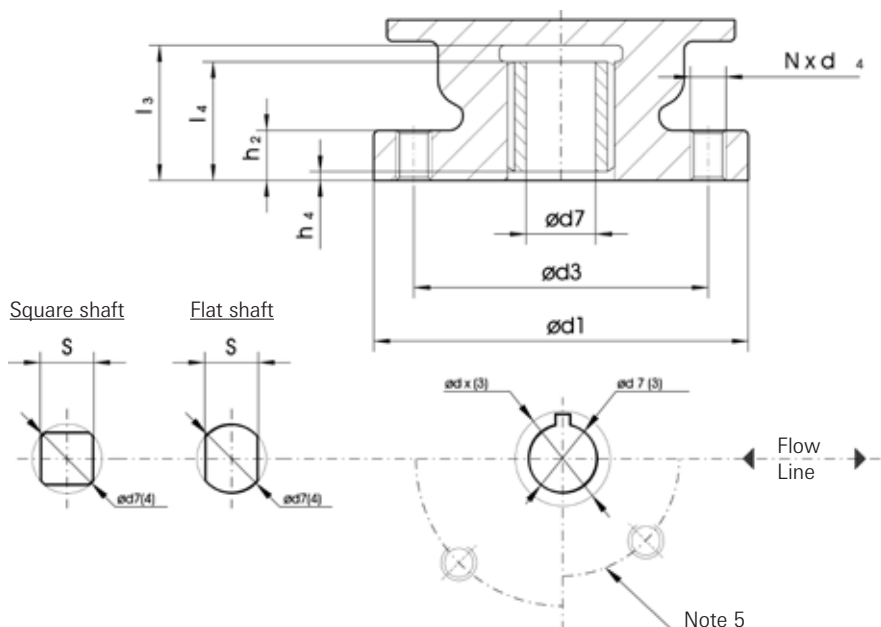

Coupling Dimensions

Actuator size	ISO	Coupling Dimensions								Max Stem Acceptance			Mass Kg	
		Ø d'	Ø d³	Ø d⁴	N	l³	l⁴	h²	h⁴	Ø d⁷	S	Ø d⁴		FL
F01-150	F10	125	102	M10	4	50	48	16	1	28	22	36	F07	32
F01-300	F10	125	102	M10	4	50	48	16	1	28	22	36	F07	32
F01-600	F12	150	125	M12	4	60	58	18	1	36	30	45	F10	34

1-phase supply at 50 Hz

Model	110V-50Hz-1Ph								230V-50Hz-1Ph							
	KW	RPM	In(A)	Is(A)	Icc(A)	PF	Eff	Cap	KW	RPM	In(A)	Is(A)	Icc(A)	PF	Eff	Cap
F01.150-052	0.040	2820	1.40	2.50	4.50	0.92	0.28	25	0.040	2820	0.70	1.25	2.30	0.92	0.28	6.3
F01.150-054	0.020	1400	0.80	1.50	2.50	0.94	0.24	16	0.020	1400	0.40	0.80	1.30	0.94	0.24	4
F01.150-056	0.014	930	0.60	1.20	2.00	0.97	0.22	12.5	0.014	930	0.30	0.60	1.00	0.97	0.22	3.5
F01.150-058	0.010	700	0.50	0.80	1.50	0.96	0.19	8	0.010	700	0.25	0.40	0.80	0.96	0.19	2
F01.300-052	0.040	2820	1.40	2.50	4.50	0.92	0.28	25	0.040	2820	0.70	1.25	2.30	0.92	0.28	6.3
F01.300-054	0.020	1400	0.80	1.50	2.50	0.94	0.24	16	0.020	1400	0.40	0.80	1.30	0.94	0.24	4
F01.300-056	0.014	930	0.60	1.20	2.00	0.97	0.22	12.5	0.014	930	0.30	0.60	1.00	0.97	0.22	3.5
F01.300-058	0.010	700	0.50	0.80	1.50	0.96	0.19	8	0.010	700	0.25	0.40	0.80	0.96	0.19	2
F01.300-102	0.080	2850	2.10	3.00	5.50	0.90	0.38	50	0.080	2850	1.00	1.50	3.00	0.90	0.40	12.5
F01.300-104	0.040	1420	1.40	2.50	4.50	0.92	0.28	25	0.040	1420	0.70	1.30	2.30	0.92	0.28	6.3
F01.600-102	0.080	2850	2.10	3.00	5.50	0.90	0.38	50	0.080	2850	1.00	1.50	3.00	0.90	0.40	12.5
F01.600-104	0.040	1420	1.40	2.50	4.50	0.92	0.28	25	0.040	1420	0.70	1.30	2.30	0.92	0.28	6.3
F01.600-106	0.030	940	1.20	2.00	3.50	0.94	0.24	20	0.030	940	0.60	1.00	1.80	0.94	0.24	5
F01.600-108	0.020	720	0.80	1.50	2.50	0.94	0.24	16	0.020	720	0.40	0.80	1.30	0.94	0.24	4

1-phase supply at 60 Hz

Model	115V-60Hz-1Ph								240V-60Hz-1Ph							
	KW	RPM	In(A)	Is(A)	Icc(A)	PF	Eff	Cap	KW	RPM	In(A)	Is(A)	Icc(A)	PF	Eff	Cap
F01.150-052	0.048	3380	1.40	2.50	4.50	0.92	0.32	20	0.048	3380	0.70	1.25	2.30	0.92	0.31	6.3
F01.150-054	0.024	1680	0.80	1.50	2.50	0.94	0.28	12.5	0.024	1680	0.40	0.80	1.30	0.94	0.27	4
F01.150-056	0.017	1120	0.60	1.20	2.00	0.97	0.25	10	0.017	1120	0.30	0.60	1.00	0.97	0.24	3.5
F01.150-058	0.012	840	0.50	0.80	1.50	0.96	0.22	6.3	0.012	840	0.25	0.40	0.80	0.96	0.20	2
F01.300-052	0.048	3380	1.40	2.50	4.50	0.92	0.32	20	0.048	3380	0.70	1.25	2.30	0.92	0.31	6.3
F01.300-054	0.024	1680	0.80	1.50	2.50	0.94	0.28	12.5	0.024	1680	0.40	0.80	1.30	0.94	0.27	4
F01.300-056	0.017	1120	0.60	1.20	2.00	0.97	0.25	10	0.017	1120	0.30	0.60	1.00	0.97	0.24	3.5
F01.300-058	0.012	840	0.50	0.80	1.50	0.96	0.22	6.3	0.012	840	0.25	0.40	0.80	0.96	0.20	2
F01.300-102	0.096	3420	2.10	3.00	5.50	0.90	0.44	40	0.096	3420	1.00	1.50	3.00	0.90	0.44	12.5
F01.300-104	0.048	1700	1.40	2.50	4.50	0.92	0.32	20	0.048	1700	0.70	1.30	2.30	0.92	0.31	6.3
F01.600-102	0.096	3420	2.10	3.00	5.50	0.90	0.44	40	0.096	3420	1.00	1.50	3.00	0.90	0.44	12.5
F01.600-104	0.048	1700	1.40	2.50	4.50	0.92	0.32	20	0.048	1700	0.70	1.30	2.30	0.92	0.31	6.3
F01.600-106	0.036	1130	1.20	2.00	3.50	0.94	0.28	16	0.036	1130	0.60	1.00	1.80	0.94	0.27	5
F01.600-108	0.024	860	0.80	1.50	2.50	0.94	0.28	12.5	0.024	860	0.40	0.80	1.30	0.94	0.27	4

Definitions

- **KW** = motor nominal power
- **RPM** = motor nominal speed in round per minute
- **In** = nominal current of the motor, according to IEC 34-1, which approximately corresponds to 40% of the actuator nominal torque
- **Is** = current which approximately corresponds to the actuator nominal torque (torque set 100%); we recommend the selection of cables and protections based on the above values
- **Icc** = locked rotor current
- **PF** = power factor
- **Eff** = motor efficiency
- **Cap** = capacitors value measured in microFarad

Motor insulation class H

Motors duty according to IEC 34-1

For ambient temperature up to +65° C: S2-30 minutes or S4-25%, max 200 starts/hour

For ambient temperature up to +85° C: S2-15 minutes or S4-25%, max 60 starts/hour

Tolerances

Nominal Voltage Tolerance: ± 6%

Nominal Frequency Tolerance: ± 2%

Momentary max permissible voltage variation: +10%; -15%

Other tolerances according to IEC 34-1

Model F01-600

Overall dimensions			
Cables entries	a	b	c
NTP	1"	1" ½	1"

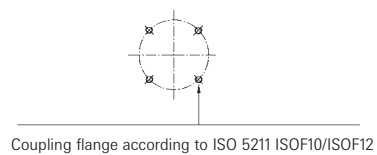
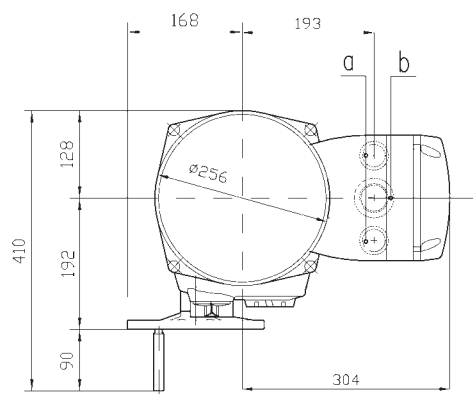
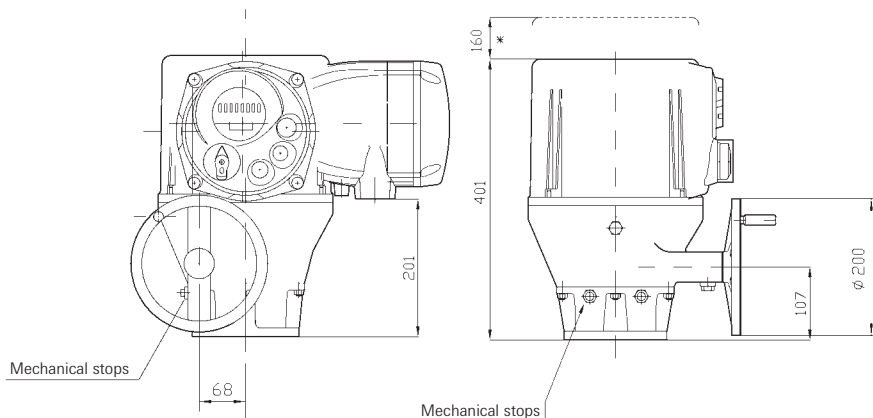

Mass 32 Kg.

*Space for cover removal

Models F01-150 & 300

Overall dimensions			
Cables entries	a	b	c
NTP	1"	1" ½	1"

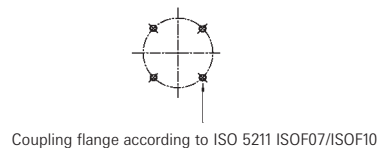
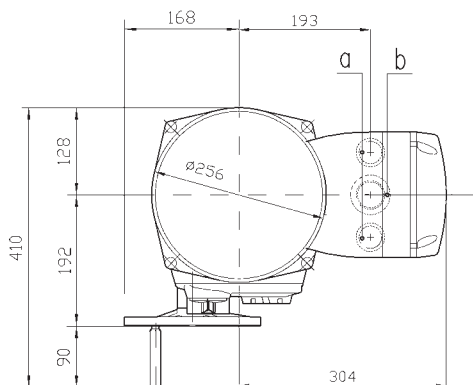
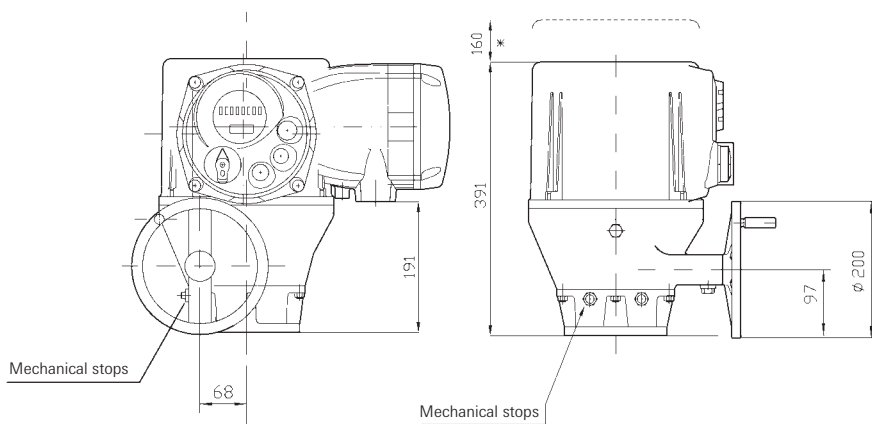

Mass 31 Kg.

*Space for cover removal