



SRV 801 / 811

Safety Relief Valves

The 801 and 811 relief valves are installed downstream of pressure regulators to relieve limited volumes of gas. Used where venting to the atmosphere is acceptable, they provide cost-effective solutions to prevent safety shut-off valves from triggering in case of thermal expansion, transient pressure surges, and creep leaks from regulators. These valves are ideal for low pressure settings due to the increased sensitivity provided by a large diaphragm area.

KEY BENEFITS

- » Compact design
- » Accurate operation
- » High flow capacity
- » Reliable
- » Tight shut-off

DESCRIPTION

The 801 and 811 relief valves are spring-loaded throttling relief valves, where a diaphragm measures the system (inlet) pressure, a spring provides the initial load to the diaphragm and establishes the relief set point, and a valve throttles the relief flow.

Technical Specifications

Maximum relief (inlet) pressure	1.5 bar
Relief set pressure range	8 - 700 mbar
Operating temperature	-20°C to +60°C
Acceptable gases	Natural gas, town gas, propane, butane, air, nitrogen or any non-corrosive gas

Sizes & Connections

Sizes	DN 1"
Type	Gas female threaded

Materials

Body-Casing-Cover	Aluminium
Valve	Nitrile Rubber
Diaphragm	Rubber, fabric reinforced
Internal Parts	Brass and Stainless Steel

Flow Capacity

Relief Set Pressure (mbar)	Buildup Over Relief Pressure Setting (mbar)	Capacity at Standard Conditions (m ³ /h)
35	3.5	18.5
35	7	29
64	6.5	22
64	13	38

Standard conditions:

- Absolute pressure of 1.013 bar
 - Temperature of 15°C
- The flow rates are indicated for a 0.6 specific gravity gas

SRV Spring Selection Tables - DN 1"

SRV	Spring Code	Spring Characteristic				Wu (mbar)	Maximum Available Relief (inlet) Pressure mbar
		d	De	Lo	Lt		
801	20563325	1.3	25	55	8	15 ÷ 30	500
	20563025	1.5	25	50	6.5	28 ÷ 70	500
	20563026	1.7	25	50	7	40 ÷ 85	500
	20563027	1.9	25	50	6.75	55 ÷ 120	500
	20563028	2.2	25	50	7.5	75 ÷ 240	500
811	20564141	1.6	30	80	9.5	8 ÷ 18	500
	20564142	1.8	30	80	8.5	16 ÷ 28	500
	20564044	2.2	30	80	9	30 ÷ 56	500
	20564042	2.5	30	80	9	40 ÷ 90	500
	20564143	3	30	80	9	90 ÷ 190	500
811/TR	20564042	2.5	30	80	9	100 ÷ 230	1500
	20564143	3	30	80	9	210 ÷ 450	1500
	20564144	3.5	30	80	9	420 ÷ 700	1500

Note: Accuracy at the initial leak point, at which the relief valve begins to discharge, is in the range of ± 5% of the setting.

Spring characteristics:

- d: wire diameter
- Lo: height
- De: external diameter
- Lt: no. of spires

Overall Dimensions (mm)

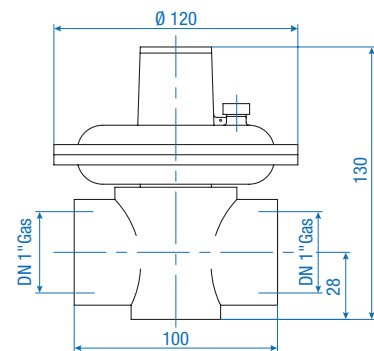

Type SRV 801 / Weight 0.8 kg

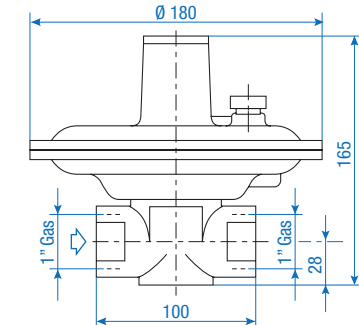

Type SRV 811 / Weight 1.2 kg

OPTIONS

SRV 811 may be fitted with a pressure tap (Ermeto 8 coupling) for system (inlet) pressure indicator - Code: SRV 811/I or SRV 811/I/TR.

SRV 811 may be fitted with a valve disk down-stream to the flow, which reduces the popping effect and allows a smooth throttling of the flow - Code: SRV 811/A or SRV 811/A/TR.

Information to be specified when ordering:

- » Model
- » Inlet pressure
- » Relief pressure range
- » Connection type
- » Maximum flow rate
- » Kind of gas
- » Quantity required



Our company is the world's leading provider of smart metering, data collection and utility software systems, with over 8,000 utilities worldwide relying on our technology to optimize the delivery and use of energy and water.

To realize your smarter energy and water future, start here: www.itron.com

For more information, contact your local sales representative or agency:

ITRON GmbH

Hardeckstraße 2
D-76185 Karlsruhe
Germany

Phone: +49-721 5981 0

Fax: +49-721 5981 189