



C SERIES ENGINEERING DATA PACK

Contents:

Pump Performance Data

- Page 2: C/4200/4300 Pump Performance Data (40, 200, 500 & 1000 SSU)
Page 3: C/4200/4300 Pump Performance Data (5000, 10000 & 25000 SSU)

C Pumps

- Page 4: General Model Descriptions
Page 5: Pump Mounting Dimensions (2C2F-6C2F with pump options)
Page 6: Pump Mounting Dimensions (2C2FA-6C2FA with pump options)
Page 7: Pump Mounting Dimensions (2C2E-6C2E with pump options)
Page 8: Pump Mounting Dimensions (2C2B-6C2B with pump options)
Page 9: Pump Mounting Dimensions (2CK1B-6CK1B with pump options)
Page 10: Pump Mounting Dimensions (2C2G-6C2G with pump options)
Page 11: Pump Mounting Dimensions (1ACS, 2-4CS & 6ACS with pump options)
Page 12: Pump Mounting Dimensions (1CSA-6CSA with pump options)
Page 13: C Pump Model Number System (Includes port options)
Page 14: Temperature Limits
Page 15: C Pump Materials of Construction
Page 16: NPSH Data
Page 17: Dimensions for 2C2F-4C2F Close Coupled to Three Phase Motors
Page 18: Dimensions for Adapter Mounting 2C2F-6C2F pumps to NEMA C Frame Motors
Page 19: Dimensions for Adapter Mounting 2C2B-6C2B & 4312-4316 & 4332-4336 pumps to NEMA C Frame Motors
Page 20: Dimensions for Adapter Mounting 2CK1B-6CK1B pumps to NEMA C Frame Motors
Page 21: Dimensions for C Series Mounting Feet (2C81, 3C81, 3CK81 & 5C81)

4200/4300 Pumps

- Page 22-23: 4000/C Cross Reference List
Page 24: Pump Mounting Dimensions (4312-4316 with pump options)
Page 25: Pump Mounting Dimensions (4212-4216 & 4232-4236 with pump options)
Page 26: Pump Mounting Dimensions (4332-4336 with pump options)
Page 27: 4200/4300 Pump Model Number System (Includes port options)
Page 28: Temperature Limits
Page 29: 4200/4300 Materials of Construction

CC Pumps

- Page 30: Pump/NEMA Motor Mounting Dimensions (CC09 size with options)
Page 31: Pump/IEC Motor Mounting Dimensions (CC09 size with options)
Page 32: Pump/NEMA Motor Mounting Dimensions (CC015, 020 & 030 size with options)
Page 33: Pump/IEC Motor Mounting Dimensions (CC015, 020 & 030 size with options)
Page 34: "CC" Series Model Number System
Page 35: Temperature Limits
Page 36: "CC" Series Materials of Construction
Page 37: NPSH Data

C/4200/4300 Pump Performance Data

SIZE	40 SSU												200 SSU												500 SSU												1000 SSU											
	0 PSI			50 PSI			100 PSI			150 PSI			0 PSI			50 PSI			100 PSI			150 PSI			0 PSI			50 PSI			100 PSI			150 PSI														
	GPM	HP	1500 RPM	GPM	HP	1500 RPM	GPM	HP	1500 RPM	GPM	HP	1500 RPM	GPM	HP	1500 RPM	GPM	HP	1500 RPM	GPM	HP	1500 RPM	GPM	HP	1500 RPM	GPM	HP	1500 RPM	GPM	HP	1500 RPM	GPM	HP	1500 RPM	GPM	HP	1500 RPM												
1	300	0.4	1/8	0.3	1/8	-	-	-	0.4	1/8	0.2	1/8	-	-	-	0.4	1/8	0.4	1/8	-	-	-	0.4	1/8	0.4	1/8	-	-	-	0.4	1/8	0.4	1/8	-	-	-												
	900	1.5	1/4	1.1	1/4	1.1	1/3	1.1	1/4	1.4	1/8	1.2	1/4	-	-	1.3	1/8	1.3	1/8	1.3	1/4	1.4	1/8	1.4	1/8	1.4	1/8	1.4	1/8	1.3	1/8	1.3	1/8	1.3	1/8	-	-											
	1200	1.9	1/4	1.7	1/4	1.5	1/3	1.5	1/8	1.9	1/8	1.7	1/4	-	-	1.8	1/8	1.8	1/8	1.7	1/4	1.9	1/8	1.9	1/8	1.9	1/8	1.9	1/8	1.8	1/4	1.8	1/8	1.8	1/4	-	-											
	1800	2.9	1/4	2.7	1/2	2.5	1/2	2.5	1/8	2.9	1/8	2.7	1/3	-	-	2.7	1/4	2.7	1/4	2.7	1/3	2.8	1/4	2.7	1/3	2.7	1/4	2.7	1/4	2.6	1/3	2.7	1/4	2.7	1/4	-	-											
2	300	-	-	-	-	-	-	-	1.5	1/8	1.2	1/4	0.8	1/4	-	-	1.6	1/8	1.4	1/4	1.2	1/4	-	-	1.6	1/4	1.6	1/4	1.4	1/3	1.4	1/3	-	-	-	-												
	900	3.8	1/4	2.4	1/2	1.2	3/4	1.2	1/4	4.5	1/4	3.3	3/4	2.2	1	4.6	1/4	4.0	1/3	3.3	3/4	2.2	1	4.6	1/4	4.0	1/3	3.3	3/4	3.0	1	4.8	1/2	4.6	1/2	3.5	1 1/2											
	1200	5.0	1/3	3.6	1/2	2.2	1	2.2	1/3	6.0	1/3	4.5	1	3.7	1 1/2	6.2	1/3	5.3	1/2	4.5	1	3.7	1 1/2	6.2	1/3	5.3	1/2	4.5	1	6.6	1/2	6.4	3/4	6.0	1	5.2	2											
	1800	7.6	1/2	6.0	3/4	4.4	1 1/2	4.4	1/2	9.0	1/2	8.0	3/4	7.0	1 1/2	9.2	1/2	8.4	1	7.5	1 1/2	7.0	2	9.2	1/2	8.4	1	7.5	1 1/2	7.0	2	9.8	3/4	9.5	1	9.0	1 1/2	8.5	3									
3	300	-	-	-	-	-	-	-	3.1	1/4	2.8	1/4	2.5	1/2	-	-	3.1	1/4	2.9	1/4	2.7	1/3	-	-	3.1	1/4	3.0	1/4	2.8	1/2	2.8	1/2	-	-	-	-												
	900	7.5	1/2	6.0	1	4.8	1 1/2	4.8	1/2	9.0	1/2	8.0	1 1/2	5.0	1 1/2	9.2	3/4	8.5	1	8.2	1 1/2	6.0	1 1/2	5.0	1 1/2	9.2	3/4	8.5	1	9.4	1	9.4	1	8.5	1 1/2	6.5	2											
	1200	10.0	3/4	8.2	1	6.3	1 1/2	6.3	1/2	12.0	3/4	11.0	1	10.5	1 1/2	12.0	1	11.5	1 1/2	11.0	2	9.0	2	11.5	1 1/2	11.0	2	9.0	2	12.5	1 1/2	12.0	1 1/2	11.8	2	9.7	3											
	1800	15.0	1	12.2	1 1/2	9.5	3	9.5	3	18.0	1	17.0	1 1/2	16.0	3	13.0	5	18.1	1 1/2	18.0	2	16.3	3	15.0	3	18.7	2	18.5	2	18.5	2	17.0	3	15.5	5	-	-											
4	300	-	-	-	-	-	-	-	6.0	1/8	5.5	1/3	5.0	1/2	-	-	6.0	1/4	5.8	1/3	5.5	1/2	-	-	6.2	1/4	5.9	1/3	5.6	3/4	5.6	3/4	-	-	-	-												
	900	15.5	3/4	12.6	1 1/2	10.0	2	10.0	3/4	18.5	3/4	17.8	1 1/2	13.0	3	18.3	1	17.8	1 1/2	17.6	2	14.0	3	17.8	1 1/2	17.6	2	14.0	3	18.7	1 1/2	18.4	2	18.0	3	15.0	3											
	1200	20.9	3/4	17.4	1 1/2	14.0	3	14.0	3/4	24.5	3/4	23.8	1 1/2	18.0	3	24.5	1 1/2	24.0	2	23.7	3	20.0	5	24.9	2	24.5	3	24.5	3	24.0	5	21.0	5	-	-	-	-											
	1800	31.2	1 1/2	26.1	3	21.0	5	21.0	5	37.0	1 1/2	36.0	3	35.0	5	30.0	5	37.0	3	36.5	5	36.0	5	32.0	7 1/2	37.4	5	37.2	5	36.5	5	33.0	7 1/2	33.0	7 1/2	-	-	-	-									
5	300	-	-	-	-	-	-	-	10.0	1/4	8.0	1/2	6.0	3/4	-	-	10.0	1/4	9.5	1/2	9.0	1	-	-	10.3	1/3	10.3	1/2	10.0	1	-	-	-	-	-	-	-	-										
	900	25.0	1	21.0	2	16.0	3	16.0	3	31.0	1	29.0	2	27.0	3	20.0	5	30.8	1 1/2	30.0	3	29.2	5	24.0	5	30.8	2	30.8	3	30.1	5	26.0	5	-	-	-	-											
	1200	34.0	1 1/2	29.0	3	22.0	5	22.0	5	41.0	1 1/2	40.0	3	38.5	5	30.0	7 1/2	41.0	2	40.0	5	39.5	5	34.0	7 1/2	41.7	3	41.7	5	41.0	5	36.0	7 1/2	-	-	-	-	-	-									
	1800	53.0	3	45.0	5	36.0	7 1/2	36.0	7 1/2	61.7	3	61.0	5	60.0	7 1/2	50.0	10	61.7	5	61.0	5	60.0	7 1/2	54.0	10	61.7	5	61.7	7 1/2	61.0	7 1/2	56.0	10	-	-	-	-	-	-									
6	300	-	-	-	-	-	-	-	14.0	1/2	12.0	3/4	10.0	1	-	-	14.0	3/4	13.5	3/4	13.0	1	-	-	14.2	3/4	14.0	1	13.0	1 1/2	-	-	-	-	-	-	-	-										
	900	36.0	1 1/2	30.0	3	23.0	5	23.0	5	42.0	1 1/2	40.0	3	38.2	5	27.0	7 1/2	42.0	2	41.0	5	40.0	5	33.0	7 1/2	42.2	3	41.5	5	40.2	5	35.0	7 1/2	-	-	-	-	-	-									
	1200	47.5	2	40.0	5	32.0	7 1/2	32.0	7 1/2	56.0	2	54.0	5	52.5	7 1/2	42.0	7 1/2	56.0	3	55.0	5	54.0	7 1/2	47.0	10	56.0	5	55.0	5	54.0	7 1/2	47.0	10	-	-	-	-	-	-									
	1800	71.0	5	61.0	7 1/2	49.0	10	49.0	10	84.0	5	83.0	7 1/2	82.0	10	70.0	10	84.0	5	83.0	7 1/2	82.0	10	75.0	15	84.0	7 1/2	83.0	7 1/2	82.0	10	76.0	15	-	-	-	-	-	-									

C/4200/4300 Pump Performance Data

SIZE	RPM	5000 SSU												10000 SSU												25000 SSU											
		0 PSI				50 PSI				100 PSI				150 PSI				0 PSI				50 PSI				100 PSI				150 PSI							
		GPM	HP	GPM	HP	GPM	HP	GPM	HP	GPM	HP	GPM	HP	GPM	HP	GPM	HP	GPM	HP	GPM	HP	GPM	HP	GPM	HP	GPM	HP	GPM	HP	GPM	HP						
1	300	-	-	-	-	-	-	-	-	-	-	-	-	-	-	-	-	-	-	-	-	-	-	-	-	-	-	-	-	-	-						
	900	-	-	-	-	-	-	-	-	-	-	-	-	-	-	-	-	-	-	-	-	-	-	-	-	-	-	-	-	-	-						
	1200	-	-	-	-	-	-	-	-	-	-	-	-	-	-	-	-	-	-	-	-	-	-	-	-	-	-	-	-	-	-						
	1800	-	-	-	-	-	-	-	-	-	-	-	-	-	-	-	-	-	-	-	-	-	-	-	-	-	-	-	-	-	-						
2	300	1.6	1/4	1.6	1/4	1.5	1/3	0.9	3/4	1.6	1/4	1.6	1/3	1.5	1/2	1.0	3/4	1.6	1/4	1.6	1/2	1.6	1/2	1.6	1/2	1.6	1/2	1.5	3/4	1.1	1						
	900	4.9	3/4	4.8	1	4.2	1 1/2	4.1	1 1/2	4.9	1	4.8	1	4.6	1 1/2	-	-	-	-	-	-	-	-	-	-	-	-	-	-	-	-						
	1200	6.5	1	6.4	1 1/2	6.2	1 1/2	-	-	-	-	-	-	-	-	-	-	-	-	-	-	-	-	-	-	-	-	-	-	-	-	-					
	1800	9.7	1 1/2	9.6	2	9.3	2	-	-	-	-	-	-	-	-	-	-	-	-	-	-	-	-	-	-	-	-	-	-	-	-	-					
3	300	3.1	1/3	3.0	1/2	2.9	3/4	1.6	3/4	3.1	1/2	3.0	3/4	2.9	3/4	2.0	1	3.1	1/2	3.0	3/4	3.0	3/4	3.0	3/4	3.0	3/4	3.0	1	2.1	1						
	900	9.4	1 1/2	9.4	1 1/2	8.7	2	7.6	3	9.0	1 1/2	8.9	2	8.8	2	-	-	-	-	-	-	-	-	-	-	-	-	-	-	-	-						
	1200	12.5	2	12.4	2	11.6	3	-	-	-	-	-	-	-	-	-	-	-	-	-	-	-	-	-	-	-	-	-	-	-	-	-					
	1800	18.7	3	18.5	3	17.5	5	-	-	-	-	-	-	-	-	-	-	-	-	-	-	-	-	-	-	-	-	-	-	-	-	-					
4	300	6.2	1/2	6.2	3/4	6.0	1	4.2	1 1/2	6.2	3/4	6.1	1	6.0	1 1/2	4.5	2	6.2	3/4	6.1	1	6.1	1	6.0	1 1/2	6.0	1 1/2	4.8	1 1/2	-	-						
	900	18.7	3	18.5	3	18.0	5	16.3	5	18.3	3	18.0	3	17.8	5	-	-	-	-	-	-	-	-	-	-	-	-	-	-	-	-	-					
	1200	24.9	5	24.9	5	24.5	5	-	-	23.3	5	23.0	5	22.8	5	-	-	-	-	-	-	-	-	-	-	-	-	-	-	-	-	-					
	1800	37.4	7 1/2	37.4	7 1/2	37.0	7 1/2	-	-	-	-	-	-	-	-	-	-	-	-	-	-	-	-	-	-	-	-	-	-	-	-	-					
5	300	10.3	1/2	10.3	1	10.0	1 1/2	7.0	2	10.3	1	10.3	1	10.0	1 1/2	7.5	2	10.3	1 1/2	10.3	1 1/2	10.3	1 1/2	10.0	2	8.0	2	-	-	-	-						
	900	30.8	3	30.8	5	30.0	5	27.0	7 1/2	30.8	5	30.8	5	30.6	5	-	-	-	-	-	-	-	-	-	-	-	-	-	-	-	-	-					
	1200	41.7	5	41.7	5	40.0	7 1/2	-	-	-	-	-	-	-	-	-	-	-	-	-	-	-	-	-	-	-	-	-	-	-	-	-					
	1800	61.7	7 1/2	61.7	7 1/2	61.0	10	-	-	-	-	-	-	-	-	-	-	-	-	-	-	-	-	-	-	-	-	-	-	-	-	-					
6	300	14.2	3/4	14.0	1	13.3	1 1/2	10.0	5	14.0	2	13.8	2	13.5	2	11.0	3	14.0	2	13.8	2	13.8	2	13.5	3	11.2	3	-	-	-	-						
	900	42.5	5	41.5	5	40.8	7 1/2	38.0	10	41.5	7 1/2	41.0	7 1/2	40.5	7 1/2	-	-	-	-	-	-	-	-	-	-	-	-	-	-	-	-	-					
	1200	56.0	7 1/2	55.5	7 1/2	54.5	10	-	-	55.5	10	55.2	10	54.7	10	-	-	-	-	-	-	-	-	-	-	-	-	-	-	-	-	-					
	1800	84.0	10	83.0	10	82.0	15	-	-	-	-	-	-	-	-	-	-	-	-	-	-	-	-	-	-	-	-	-	-	-	-	-					

General Model Descriptions

2C2F-6C2F (Shaft Lip Seal):

Model C2F pumps were specifically developed for flange mounting applications and for close coupling to Tuthill's special motors to provide extremely compact close-coupled combinations (See Page 17). Model C2F pumps are supplied with a single spring-loaded lip seal, and can handle inlet pressures to 25 PSI. Designed for direct drive service, these pumps incorporate precision bronze bearings and may be also supplied with a shaft modification for driving the pump directly from existing shafts without couplings. The C2F pumps have a maximum differential capability of 100 PSI.

2C2FA-6C2FA (Seal less Design):

Model C2FA pumps are similar in construction to the C2F pumps. They are supplied without a seal for use on OEM built-in applications. The C2FA pumps have a maximum differential capability of 100 PSI.

2C2E-6C2E (Shaft Lip Seal With Foot Mount):

For direct-drive service, the C2E pumps have been designed to provide the maximum in compactness. C2E pumps have a spring-loaded lip seal and precision bronze bearings similar to the C2F models. C2EN pumps have an outboard ball bearing and were specifically developed for use with belt drives or similar applications where a side load is applied to the pump shaft. Both C2E and C2EN have an integral mounting foot for a variety of mounting arrangements. Both models can handle inlet pressure to 25 PSI and maximum differential pressures to 100 PSI.

2C2B-6C2B & 4312-4316 & 4332-4336 (Shaft Mechanical Seal):

Model C2B/4300 pumps are designed for flange or foot mounting applications. They may also be adapter mounted to "C" face electric motors (See Page 19). C2B/4300 pumps are provided with a mechanical seal capable of handling inlet pressures to 250 PSI at a standard 1725-RPM motor speed with a maximum discharge pressure of 300 PSI. The maximum differential for this pump is 150 PSI. For side load applications an outboard ball bearing feature is available as well.

2CK1B-6CK1B (Shaft Mechanical Seal):

Model CK1B pumps are designed for differential pressures to 250 PSI and incorporate a double ball bearing with an inboard heavy-duty roller bearing. They may also be adapter mounted to "C" face electric motors (See Page 20). CK1B pumps are supplied with a mechanical seal capable of handling inlet pressures to 250 PSI at a standard 1725-RPM motor speed with a maximum discharge pressure of 300 PSI.

2C2G-6C2G & 4212-4216 & 4232-4236 (Packing Seal With Foot Mount):

Model C2G/4200 pumps have spring loaded Teflon V-rings (Graphite Impregnated) as the shaft seal. They are capable of handling inlet pressures to 25 PSI and differential pressures to 100 PSI.

1ACS, 2-4CS, 6ACS & 1CSA-6CSA (Stripped Pumps):

Tuthill's C Series pumps are available in stripped form for use in volume OEM applications where a pump is to be built directly into a piece of equipment.

The capacity data on pages 2 and 3 may be used as a guide, although the ultimate capacities obtained will depend not only on the pumping element but the mountings provided by the customer and the tolerances the customer maintains. The stripped pumps are similar to the C2FA pumps but without a mounting bracket. This, of course, also eliminates the seal and bearing. The customer must provide these in building these models into the equipment.

These pumps are also available in a further stripped form. The CSA pumps are only supplied with the pumping elements; cover, idler gear, and rotor. The housing, bearing, bracket, and seal are not furnished.

2C2F-6C2F Pump Mounting Dimensions

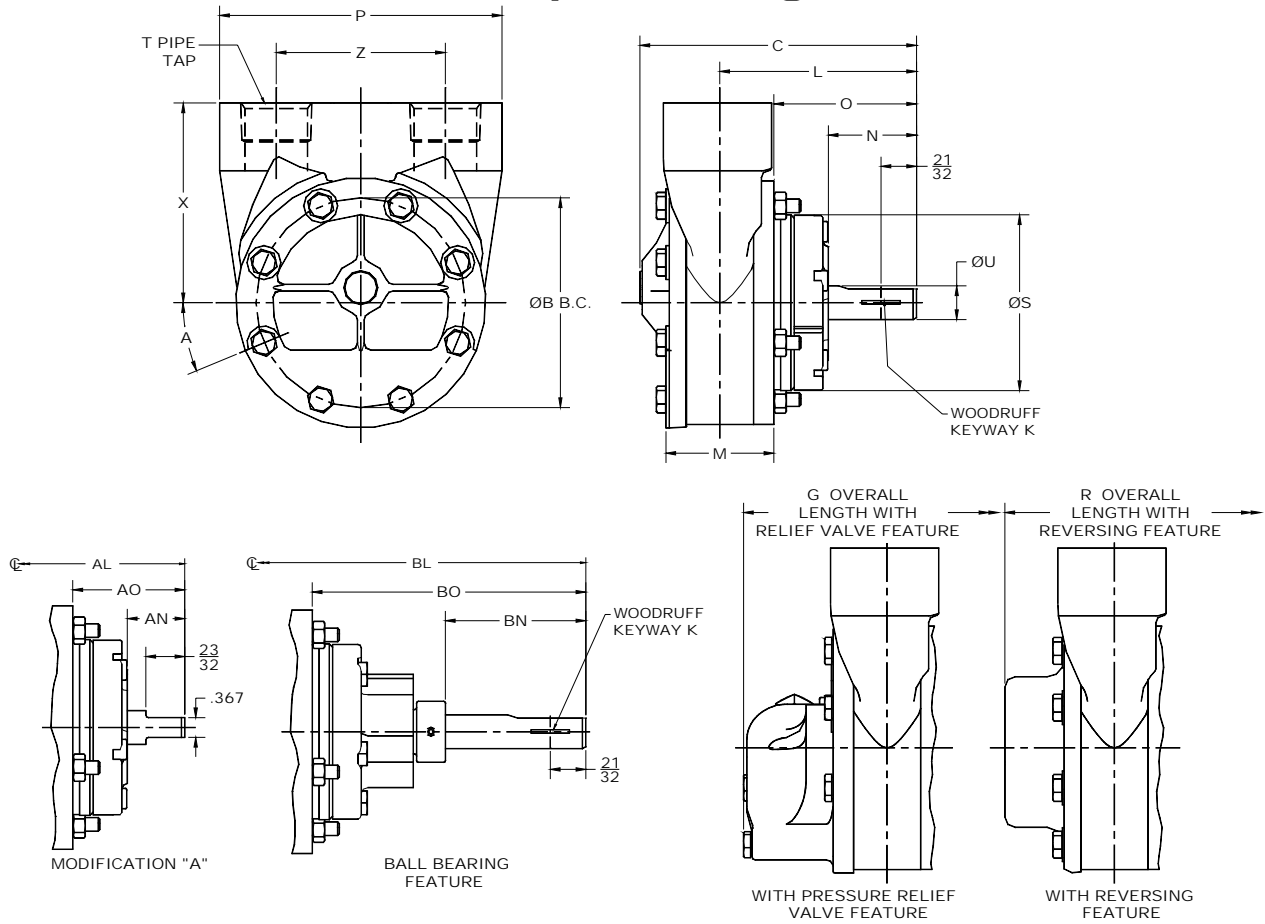

Model	A	B	C	R	G	K	L	M	N	O	P	S
2C2F	22 1/2°	3 7/8	5 1/8	5 21/32	6 7/32	#406	3 5/8	2	1 5/8	2 5/8	5 7/32	3 1/4
3C2F	22 1/2°	5 1/8	6 17/32	6 7/8	7 17/32	#606	4 13/16	2 5/16	2 3/32	3 7/16	6 5/8	3 3/4
4C2F	22 1/2°	5 1/8	7 27/32	7 9/16	8 7/32	#606	4 29/32	3	2 3/32	3 7/16	6 1/2	3 3/4
5C2F	17°	6 5/8	9 1/16	11 5/8	10 1/4	#808	5 3/4	4 5/16	2 3/8	3 3/8	7 1/2	3 3/4
6C2F	17°	6 5/8	9 1/2	12 1/8	10 3/4	#808	6	4 13/16	2 3/8	3 3/8	8 1/8	3 3/4

Model	T	U	X	Z	AL	AN	AO	BL	BN	BO
2C2F	1" NPT	5/8	3 11/16	3 1/8	3 1/16	1 1/16	2 1/16	6 1/16	2 19/32	5 1/32
3C2F	1 1/4" NPT	3/4	4 7/8	4 1/8	3 7/16	23/32	2 1/16	6 13/16	2 25/32	5 7/16
4C2F	1 1/2" NPT	3/4	4 1/8	3 3/4	3 17/32	23/32	2 1/16	6 29/32	2 25/32	5 7/16
5C2F	1 1/2" NPT	1	5	4 3/4	4 1/4	7/8	1 7/8	6 7/8	1 29/32	4 1/2
6C2F	2" NPT	1	4 3/4	4 3/4	4 1/2	7/8	1 7/8	7 1/8	1 29/32	4 1/2

2C2FA-6C2FA Pump Mounting Dimensions

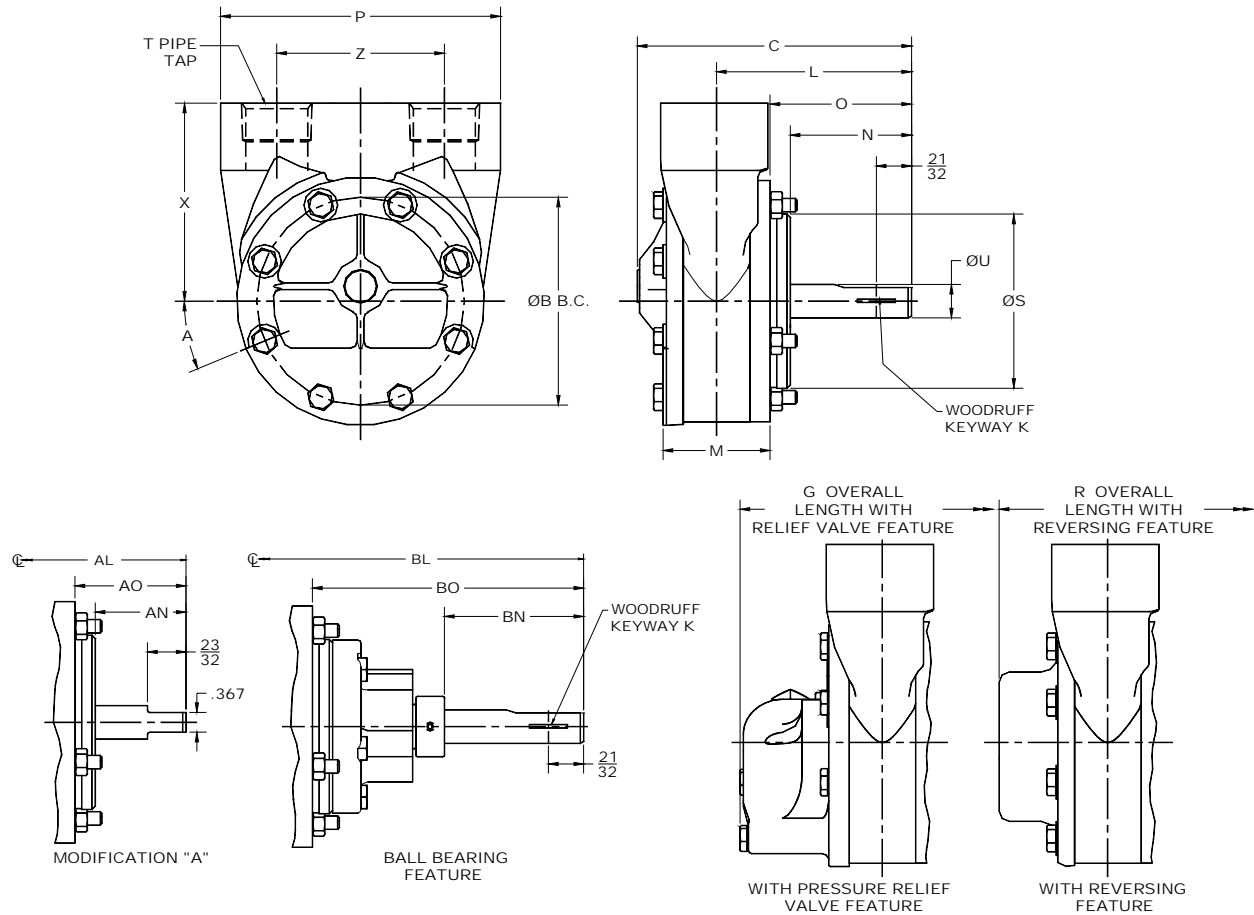

Model	A	B	C	R	G	K	L	M	N	O	P	S
2C2FA	22 1/2°	3 7/8	5 1/8	5 21/32	6 7/32	#406	3 5/8	2	2 1/8	2 5/8	5 7/32	3 1/4
3C2FA	22 1/2°	5 1/8	6 17/32	6 7/8	7 17/32	#606	4 13/16	2 5/16	2 19/32	3 7/16	6 5/8	3 3/4
4C2FA	22 1/2°	5 1/8	7 27/32	7 9/16	8 7/32	#606	4 29/32	3	2 19/32	3 7/16	6 1/2	3 3/4
5C2FA	17°	6 5/8	9 1/16	11 5/8	10 1/4	#808	5 3/4	4 5/16	2 3/4	3 3/8	7 1/2	3 3/4
6C2FA	17°	6 5/8	9 1/2	12 1/8	10 3/4	#808	6	4 13/16	2 3/4	3 3/8	8 1/8	3 3/4

Model	T	U	X	Z	AL	AN	AO	BL	BN	BO
2C2FA	1" NPT	5/8	3 11/16	3 1/8	3 1/16	1 9/16	2 1/16	6 1/16	2 19/32	5 1/32
3C2FA	1 1/4" NPT	3/4	4 7/8	4 1/8	3 7/16	1 7/32	2 1/16	6 13/16	2 25/32	5 7/16
4C2FA	1 1/2" NPT	3/4	4 1/8	3 3/4	3 17/32	1 7/32	2 1/16	6 29/32	2 25/32	5 7/16
5C2FA	1 1/2" NPT	1	5	4 3/4	4 1/4	1 1/4	1 7/8	6 7/8	1 29/32	4 1/2
6C2FA	2" NPT	1	4 3/4	4 3/4	4 1/2	1 1/4	1 7/8	7 1/8	1 29/32	4 1/2

2C2E-6C2E Pump Mounting Dimensions

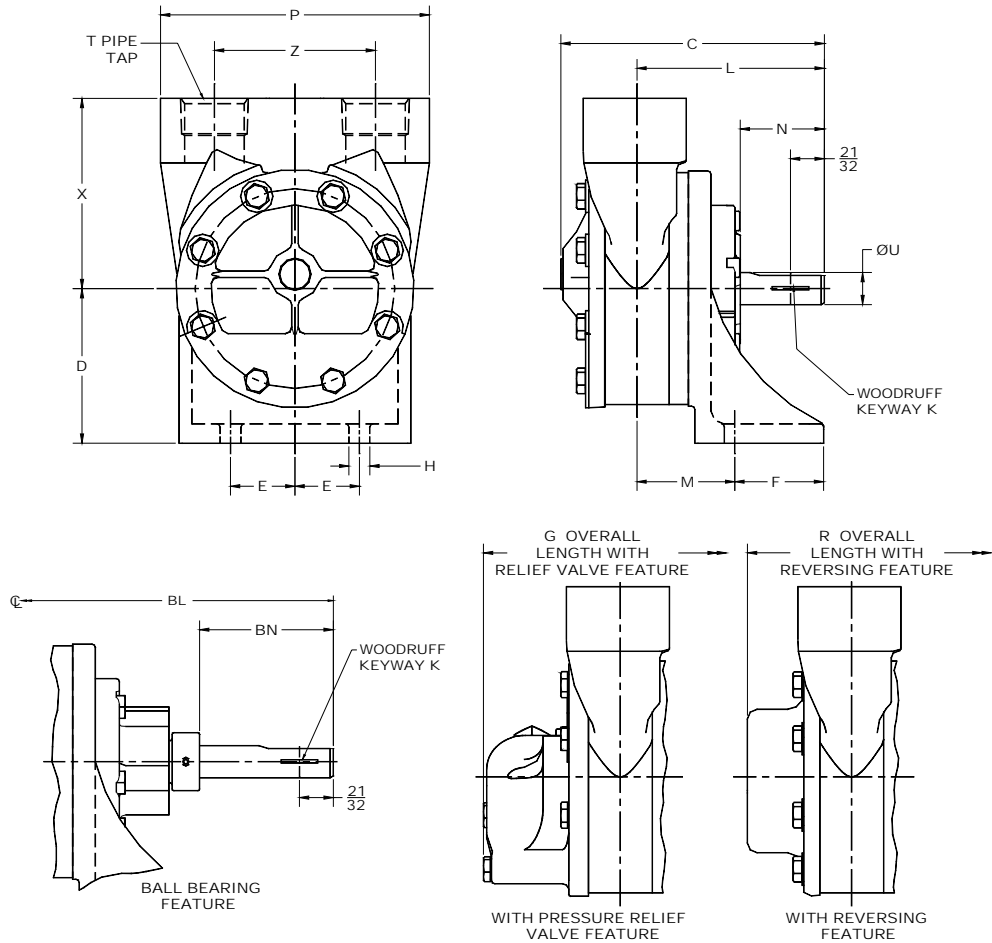

Model	C	R	G	D	E	F	H	K	L	M	N	P
2C2E	5 1/8	5 21/32	6 7/32	3	1 1/4	1 19/32	13/32	#406	3 5/8	1 29/32	1 5/8	5 7/32
3C2E	6 17/32	6 7/8	7 17/32	3 7/8	1 1/2	SLOT	15/32	#606	4 13/16	SLOT	2 3/32	6 5/8
4C2E	7 27/32	7 9/16	8 7/32	3 7/8	1 1/2	SLOT	15/32	#606	4 29/32	SLOT	2 3/32	6 1/2
5C2E	10 3/16	12 3/4	11 3/8	4 3/4	1 1/2	SLOT	15/32	#808	6 7/8	SLOT	3 1/2	7 1/2
6C2E	10 5/8	13 1/4	11 7/8	4 3/4	1 1/2	SLOT	15/32	#808	7 1/8	SLOT	3 1/2	8 1/8

Model	T	U	X	Z	BL	BN
2C2E	1" NPT	5/8	3 11/16	3 1/8	6 1/16	2 19/32
3C2E	1 1/4" NPT	3/4	4 7/8	4 1/8	6 13/16	2 25/32
4C2E	1 1/2" NPT	3/4	4 1/8	3 3/4	6 29/32	2 25/32
5C2E	1 1/2" NPT	1	5	4 3/4	6 7/8	1 29/32
6C2E	2" NPT	1	4 3/4	4 3/4	7 1/8	1 29/32

2C2B-6C2B Pump Mounting Dimensions

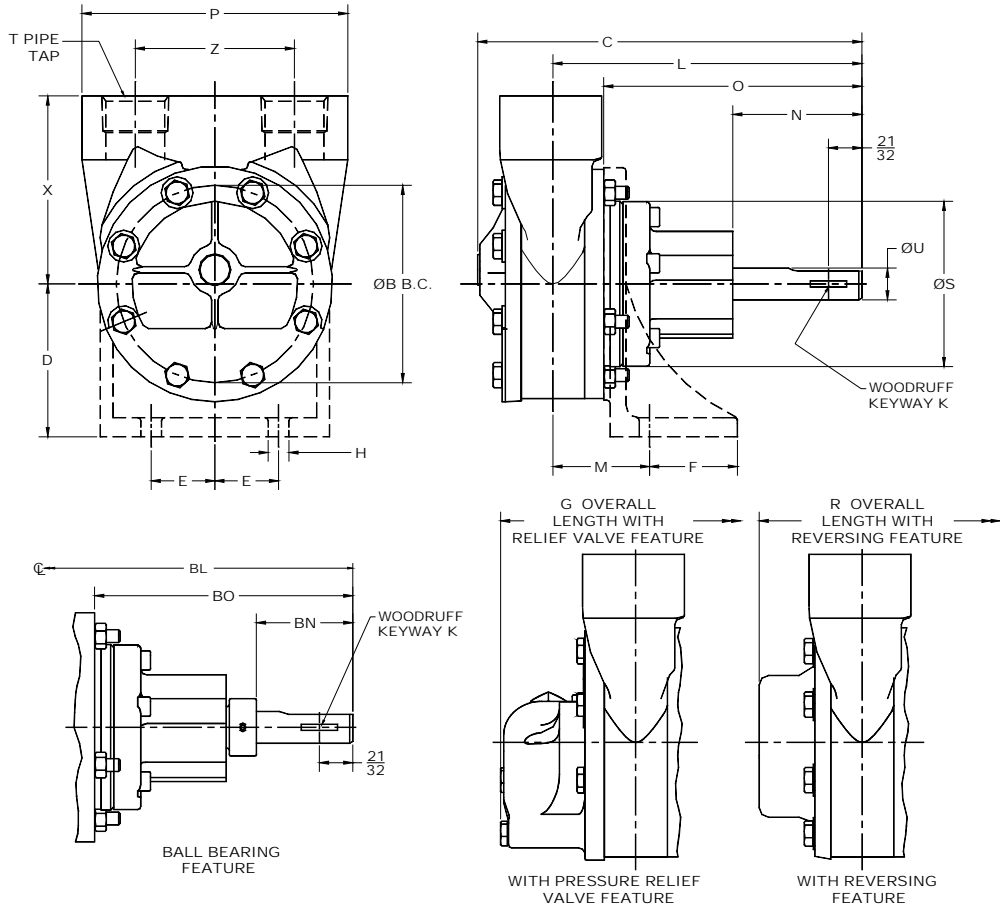

Model	C	B	R	G	D	E	F	H	K	L	M	N
2C2B	7 9/16	3 7/8	8 3/32	8 21/32	3	1 1/4	1 19/32	13/32	#406	6 1/16	1 29/32	2 17/32
3C2B	8 17/32	5 1/8	8 7/8	9 17/32	3 7/8	1 1/2	SLOT	15/32	#606	6 13/16	SLOT	2 1/2
4C2B	9 27/32	5 1/8	9 9/16	10 7/32	3 7/8	1 1/2	SLOT	15/32	#606	6 29/32	SLOT	2 1/2
5C2B	11 15/16	6 5/8	14 1/2	13 1/8	4 3/4	1 1/2	SLOT	15/32	#808	8 5/8	SLOT	3 13/32
6C2B	12 3/8	6 5/8	15	13 5/8	4 3/4	1 1/2	SLOT	15/32	#808	8 7/8	SLOT	3 13/32

Model	O	P	S	T	U	X	Z	BL	BN	BO
2C2B	5 1/16	5 7/32	3 1/4	1" NPT	5/8	3 11/16	3 1/8	6 1/16	1 27/32	5 1/16
3C2B	5 7/16	6 5/8	3 3/4	1 1/4" NPT	3/4	4 7/8	4 1/8	6 13/16	1 25/32	5 7/16
4C2B	5 7/16	6 1/2	3 3/4	1 1/2" NPT	3/4	4 1/8	3 3/4	6 29/32	1 25/32	5 7/16
5C2B	6 1/4	7 1/2	3 3/4	1 1/2" NPT	1	5	4 3/4	8 5/8	2 9/16	6 1/4
6C2B	6 1/4	8 1/8	3 3/4	2" NPT	1	4 3/4	4 3/4	8 7/8	2 9/16	6 1/4

2CK1B-6CK1B Pump Mounting Dimensions

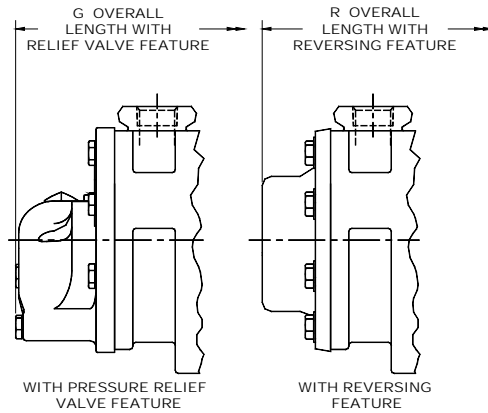
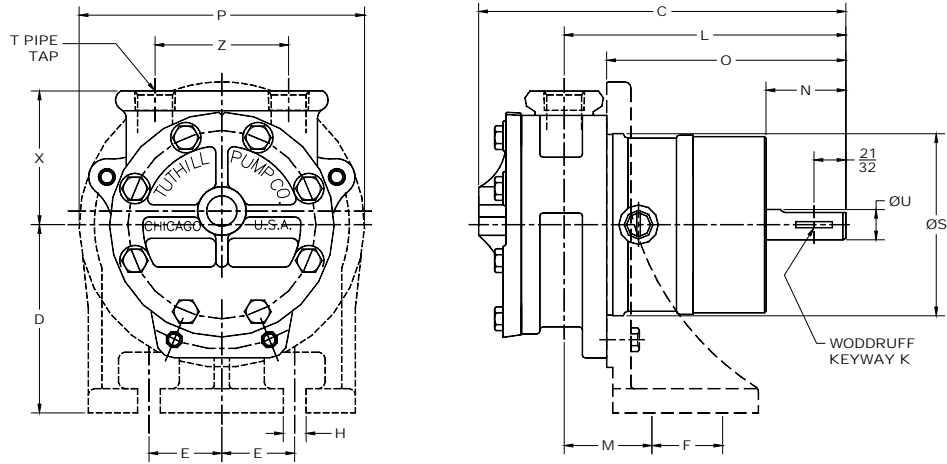

Model	C	R	G	D	E	F	H	K	L	M	N	O
2CK1B	7 9/16	8 1/16	8 21/32	3 7/8	1 1/2	SLOT	15/32	#406	5 13/16	SLOT	1 5/8	4 15/16
3CK1B	8 17/32	8 7/8	9 17/32	3 7/8	1 1/2	SLOT	15/32	#606	6 1/2	SLOT	1 5/8	5 5/8
4CK1B	9 27/32	9 9/16	10 7/32	3 7/8	1 1/2	SLOT	15/32	#606	6 13/16	SLOT	1 5/8	5 5/8
5CK1B	11 15/16	14 1/2	13 1/8	4 3/4	1 1/2	SLOT	15/32	#808	8 5/16	SLOT	2	6 13/16
6CK1B	12 3/8	15	13 5/8	4 3/4	1 1/2	SLOT	15/32	#808	8 9/16	SLOT	2	6 13/16

Model	P	S	T	U	X	Z
2CK1B	5 7/8	3 3/4	1/2" NPT	5/8	2 3/4	2 3/4
3CK1B	5 7/8	3 3/4	3/4" NPT	3/4	3 5/8	3 1/2
4CK1B	6	3 3/4	1" NPT	3/4	3 5/8	3 3/4
5CK1B	7 5/8	3 3/4	1 1/4" NPT	1	4 5/16	4 3/4
6CK1B	8 1/8	3 3/4	2" NPT	1	4 3/4	4 3/4

2C2G-6C2G Pump Mounting Dimensions

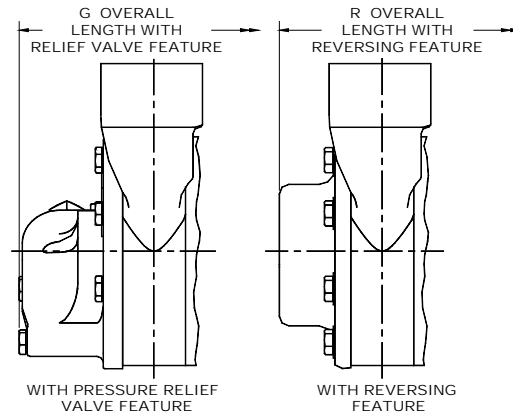
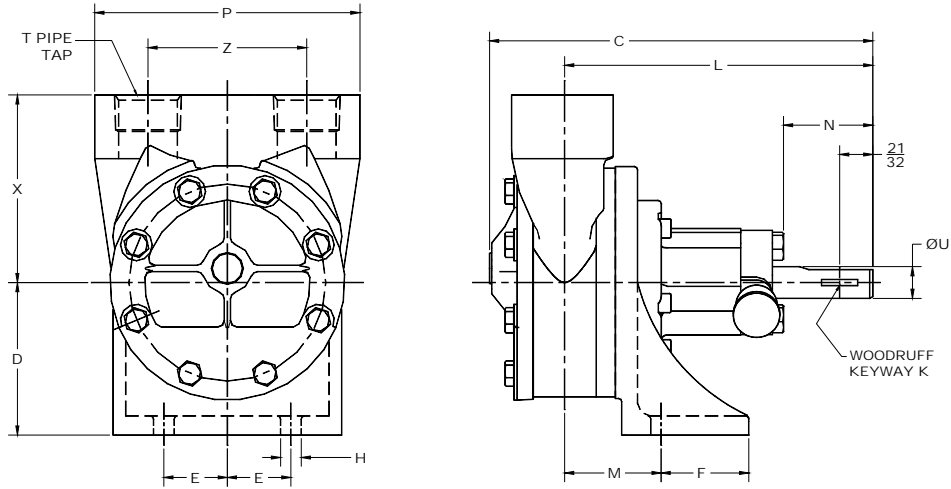

Model	C	R	G	D	E	F	H	K	L	M	N	P
2C2G	7 9/16	8 3/32	8 21/32	3	1 1/4	1 19/32	13/32	#606	6 1/16	1 29/32	1 11/16	5 7/32
3C2G	8 17/32	8 7/8	9 17/32	3 7/8	1 1/2	SLOT	15/32	#606	6 13/16	SLOT	1 13/16	6 5/8
4C2G	9 27/32	9 9/16	10 7/32	3 7/8	1 1/2	SLOT	15/32	#606	6 29/32	SLOT	1 13/16	6 1/2
5C2G	11 15/16	14 1/2	13 1/8	4 3/4	2 3/16	1 5/8	15/32	#808	8 5/8	3 3/16	2 21/32	7 1/2
6C2G	12 3/8	15	13 5/8	4 3/4	2 3/16	1 5/8	15/32	#808	8 7/8	3 7/16	2 21/32	8 1/8

Model	T	U	X	Z
2C2G	1" NPT	5/8	3 11/16	3 1/8
3C2G	1 1/4" NPT	3/4	4 7/8	4 1/8
4C2G	1 1/2" NPT	3/4	4 1/8	3 3/4
5C2G	1 1/2" NPT	1	5	4 3/4
6C2G	2" NPT	1	4 3/4	4 3/4

2CS-6CS Pump Mounting Dimensions

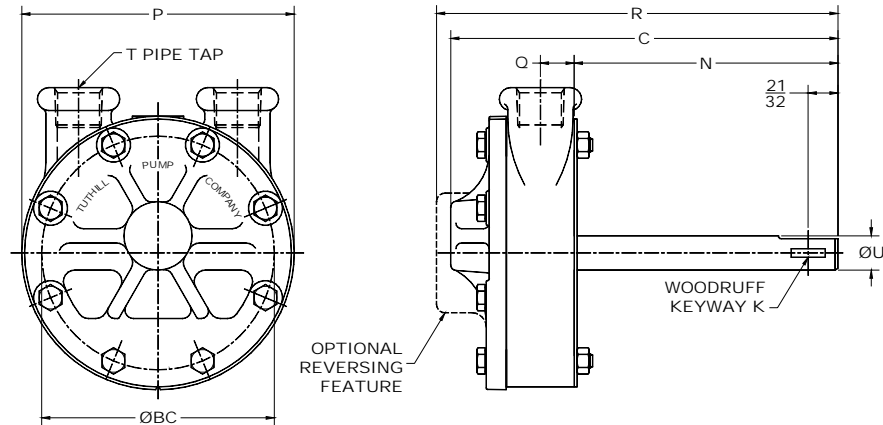

Model	BC	C	R	K	N	P	Q	T	U
1ACS	2 7/8	6 1/8	6 1/2	#204	4 3/8	3 1/2	1/2	3/8" NPT	<u>.499</u> .498
2CS	3 7/8	7 9/16	8 1/16	#406	5 7/16	4 5/8	5/8	1/2" NPT	<u>.624</u> .623
3CS	5 1/8	8 1/2	8 7/8	#606	5 13/16	6	3/4	3/4" NPT	<u>.749</u> .748
4CS	5 1/8	9 1/4	9 9/16	#606	5 13/16	6	1 1/4	1" NPT	<u>.749</u> .748
5CS	6 5/8	11 7/8	14 1/2	#808	7 1/4	7 1/2	1 3/8	1 1/4" NPT	<u>.999</u> .998
6ACS	6 5/8	12 3/8	15	#808	7 1/4	7 1/2	1 5/8	2" NPT	<u>.999</u> .998

2CSA-6CSA Pump Mounting Dimensions

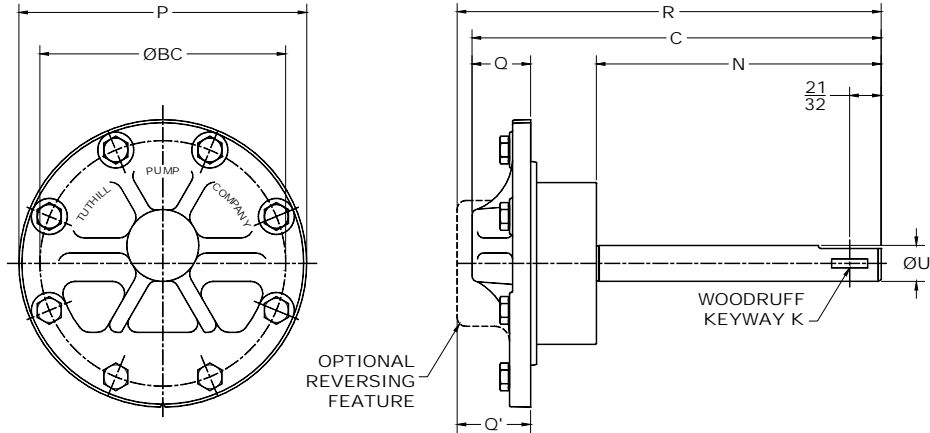

Model	BC	C	R	K	N	P	Q	Q'	U
1CSA	2 7/8	6 1/8	6 1/2	#204	4 1/2	3 1/2	11/16	1 1/8	.499 .498
2CSA	3 7/8	7 9/16	8 1/16	#406	5 9/16	4 5/8	3/4	1 5/16	.624 .623
3CSA	5 1/8	8 1/2	8 7/8	#606	5 15/16	6	1 1/4	1 11/16	.749 .748
4CSA	5 1/8	9 1/4	9 9/16	#606	5 15/16	6	1 7/8	1 11/16	.749 .748
5CSA	6 5/8	11 7/8	14 1/2	#808	7 7/16	7 1/2	1 15/16	4 1/2	.999 .998
6CSA	6 5/8	12 3/8	15	#808	7 7/16	7 1/2	1 15/16	4 1/2	.999 .998

C Pump Model Number System

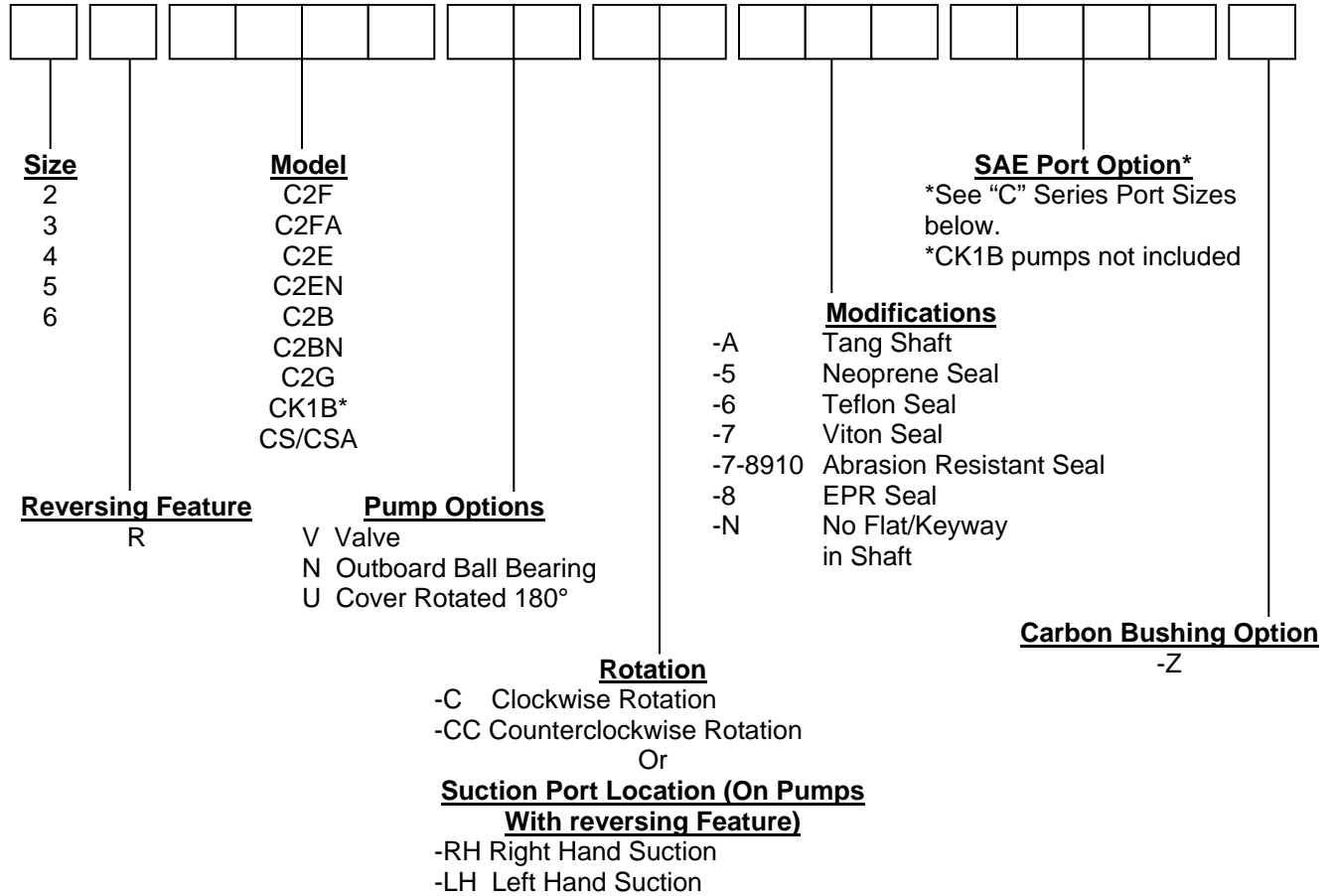

C Pump Port Sizes

Port		Pump Size				
Style	Size	2	3	4	5	6
NPT	1"	STD.	-	-	-	-
	1 1/4"	-	STD.	-	-	-
	1 1/2"	-	-	STD.	STD.	-
	2"	-	-	-	-	STD.
BSPP	1"	OPT.	-	-	-	-
	1 1/4"	-	OPT.	-	-	-
	1 1/2"	-	-	OPT.	OPT.	-
BSPT	1"	OPT.	-	-	-	-
	1 1/4"	-	OPT.	-	-	-
SAE	14	OPT.	-	-	-	-
	16	OPT.	OPT.	-	-	-
	20	-	OPT.	OPT.	-	-
	24	-	-	OPT.	OPT.	-
	32	-	-	-	-	OPT.

Model Number Location

Stamped on a metal tag on the cover

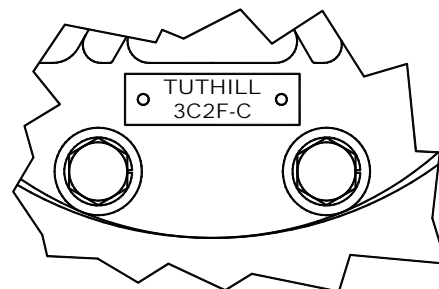

*Note: Contact factory for non-std. ports on CK1B style pumps.

C Pump Temperature Limits

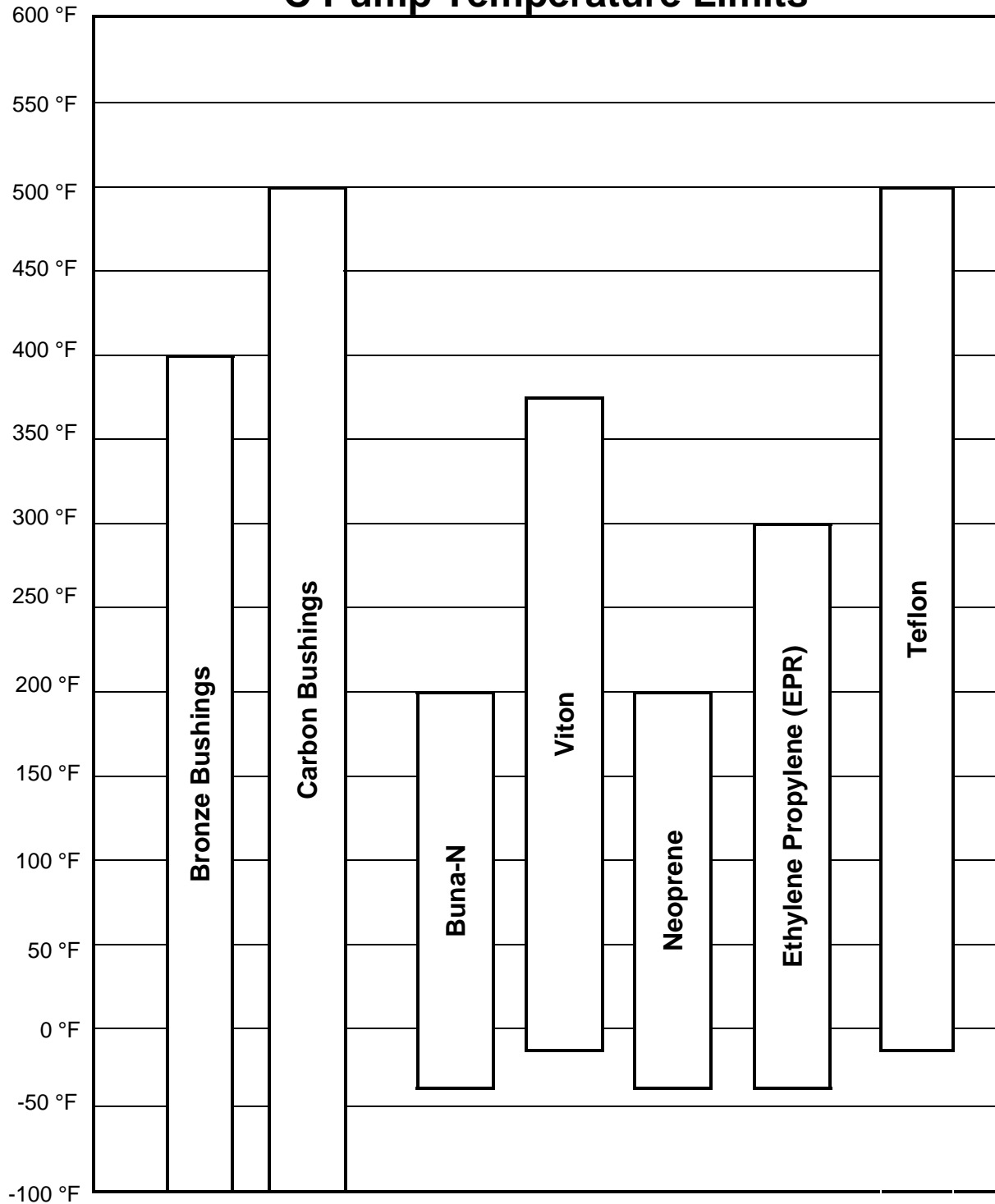

Notes:

1. A pump's performance is dependent on more than just the temperature ranges of the component materials.

C Pump Materials of Construction

Part Name	Material	Standard	Comments	Availability
Housing	Cast Iron	ASTM A48 – 96a	Classes 25, 30, 35, or 40	Std.
Bracket	Cast Iron	ASTM A48 – 96a	Classes 25, 30, 35, or 40	Std.
Bracket Bushing	Bronze	SAE 660		Std.
	Carbon	Carbon Graphite Resin		Opt.
Cover	Cast Iron	ASTM A48 – 96a	Classes 25, 30, 35, or 40	Std.
Rotor	Steel	C1137 or C1141	Steel Forging	Std.
Idler	P/M Steel	FC-0508-P		Std.
	Steel	C1117		Opt.
Idler Pin	Steel	C1117	Heat Treated	Std.
Idler Bushing	Bronze	SAE 660		Std.*
	Carbon	Carbon Graphite Resin		Opt.
Seal Gland	Cast Iron	ASTM A48 – 96a	Classes 25, 30, 35, or 40	Std.
	DU Bushing		Only on C2B models	
Packing Gland	Cast Iron	ASTM A48 – 96a	Only on C2G models	Std.
	Bronze	SAE 660		
O-Rings	Buna			Std.
	Viton			Opt.
	Neoprene			Opt.
	EPR			Opt.
	Teflon			Opt.

* Bronze idler bushing standard on 3-6 size pumps (2 size available with steel idler gear).

C Pump NPSH Data

NPSH Required for Tuthill "C" Pumps 0-1000 SSU

SPEED RPM PUMP SERIES		300	600	900	1200	1500	1800
		2	FT.	1.2	2.0	2.8	3.8
3	FT.	1.4	2.4	3.6	5.2	7.1	9.4
4	FT.	1.6	2.7	4.4	6.5	9.1	12.2
5	FT.	1.8	3.0	5.2	8.2	11.9	16.2
6	FT.	2.0	3.3	6.0	9.9	14.8	20.1

Notes:

1. For liquid viscosity up to 1000 SSU.
2. NPSHA (Net Positive Suction Head Available) must be greater than the NPSHR (Net Positive Suction Head Required) value provided in the table.
3. Values above are for feet of liquid with a Specific Gravity of 1.0.

Viscosity Correction Factor

	Viscosity (SSU)			
	2500	5000	10000	25000
Correction Factor	1.3	1.7	2.0	2.7

Dimensions for 2C2F-4C2F Close Coupled to Three Phase Motors

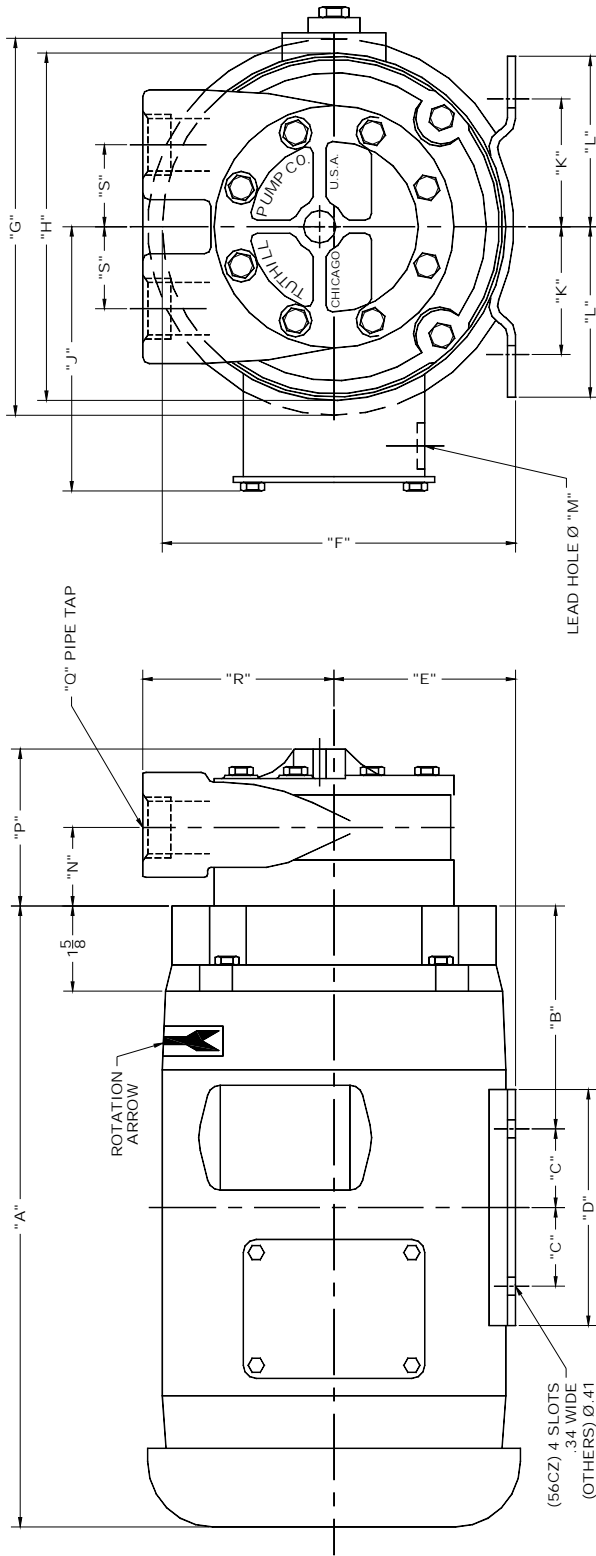

MODEL #	"N"	"P"	"R"	"S"	"O"-NPT
2C2F	1 1/32	2 1/32	3 1/16	1 9/16	1-11 1/2
3C2F	1 3/8	3 3/32	4 7/8	2 1/16	1 1/4-11 1/2
4C2F	1 15/32	4 13/32	4 1/8	1 7/8	1 1/2-11 1/2

ASSEMBLY STYLES

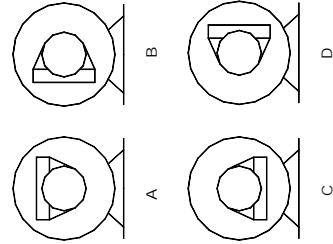

MODEL #	HP	DESCRIPTION	"A"	"B"	"C"	"D"	"E"	"F"	"G"	"H"	"J"	"K"	"L"	"M"	WT.
88501	3/4	3PH/50/60/190/380/220/440 VOLT, 208-220/440 VOLT, 1425/1725 RPM, TEFC, 56CZ FRAME	11.81	4.20	1.50	4.50	3.50	6.81	7.16	6.62	5.22	2.44	3.25	.88	26
88502	3/4	3PH/50/60/190/380/220/440 VOLT, 208-220/440 VOLT, 950/1125 RPM, TEFC, 56CZ FRAME	12.81	4.20	1.50	4.50	3.50	6.81	7.16	6.62	5.22	2.44	3.25	.88	35
88503	1	3PH/50/60/190/380/220/440 VOLT, 208-220/440 VOLT, 1425/1725 RPM, TEFC, 56CZ FRAME	11.81	4.20	1.50	4.50	3.50	6.81	7.16	6.62	5.22	2.44	3.25	.88	28
88504	1	3PH/50/60/190/380/220/440 VOLT, 208-220/440 VOLT, 950/1125 RPM, TEFC, 184CZ FRAME	13.81	4.25	2.75	6.50	4.50	8.44	8.50	7.88	5.97	3.75	4.31	1.09	50
88505	1 1/2	3PH/50/60/190/380/220/440 VOLT, 208-220/440 VOLT, 1425/1725 RPM, TEFC, 184CZ FRAME	13.81	4.25	2.75	6.50	4.50	8.44	8.50	7.88	5.97	3.75	4.31	1.09	51
88506	1 1/2	3PH/50/60/190/380/220/440 VOLT, 208-220/440 VOLT, 950/1125 RPM, TEFC, 184CZ FRAME	15.19	4.25	2.75	6.50	4.50	8.44	8.50	7.88	5.97	3.75	4.31	1.09	57
88507	2	3PH/50/60/190/380/220/440 VOLT, 208-220/440 VOLT, 1425/1725 RPM, TEFC, 184CZ FRAME	13.81	4.25	2.75	6.50	4.50	8.44	8.50	7.88	6.00	3.75	4.31	1.09	55
88493	2	3PH/50/60/190/380/220/440 VOLT, 208-220/440 VOLT, 950/1125 RPM, TEFC, 213CZ FRAME	16.68	4.88	2.75	6.50	5.25	9.16	8.50	7.88	5.97	4.25	4.75	1.06	71
88508	3	3PH/50/60/190/380/220/440 VOLT, 208-220/440 VOLT, 1425/1725 RPM, TEFC, 213CZ FRAME	15.18	4.88	2.75	6.50	5.25	9.16	8.50	7.88	5.97	4.25	4.75	1.06	55
88509	3	3PH/50/60/190/380/220/440 VOLT, 208-220/440 VOLT, 950/1125 RPM, TEFC, 215CZ FRAME	16.03	4.25	3.50	8.00	5.25	10.03	10.62	9.56	7.46	4.25	4.75	1.09	71

Dimensions for Adapter Mounting 2C2F-6C2F pumps to NEMA C Frame Motors

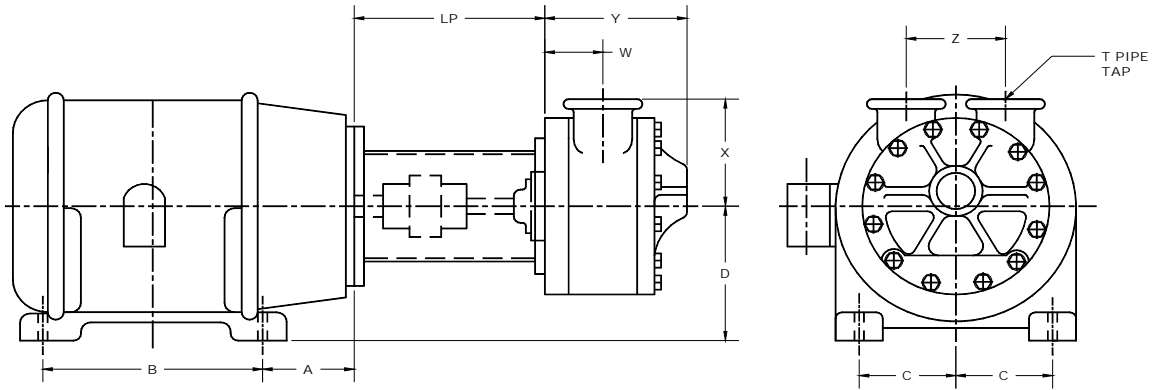

Pump Model	Motor Frame Size	LP	Adapter	Adapter Kit
2C2F	56C	5 11/16	2CF51	2CF534
	143TC, 145TC	5 11/16	2CF51	2CF534A
	182TC, 184TC	6 1/8	2C1F51-182	2C1F534-182
3C2F 4C2F	56C	6 1/4	3CF51	3CF534
	143TC, 145TC	6 1/4	3CF51	3CF534A
	182TC, 184TC	6 15/16	3C1F51-182	3C1F534-182
	213TC, 215TC	7 11/16	3C1F51-213	3C1F534-213
5C2F 6C2F	182TC, 184TC	6 7/8	5C1F51-182	5C1F534-182
	213TC, 215TC	7 5/8	5C1F51-213	5C1F534-213
	254TC, 256TC	8 5/16	5C1F51-254	5C1F534-254
	284TC, 286TC	9 1/4	5C1F51-284	5C1F534-284
	324TC, 326TC	9 3/4	5C1F51-324	5C1F534-324

Pump Model	T	W	X	Y	Y DIM WITH RELIEF VALVE	Z
2C2F	1" NPT	1	3 11/16	2 1/2	3 19/32	3 1/8
3C2F	1 1/4" NPT	1 3/8	4 7/8	3 3/32	4 3/32	4 1/8
4C2F	1 1/2" NPT	1 15/32	4 1/8	4 13/32	5 13/32	3 3/4
5C2F	1 1/2" NPT	2 3/8	5	5 11/16	6 15/16	4 3/4
6C2F	2" NPT	2 5/8	4 3/4	6 1/8	7 3/8	4 3/4

Motor Frame	A	B	C	D
56C	2 3/4	3	2 7/16	3 1/2
143TC	2 1/4	4	2 3/4	3 1/2
145TC	2 1/4	5	2 3/4	3 1/2
182TC	2 3/4	4 1/2	3 3/4	4 1/2
184TC	2 3/4	5 1/2	3 3/4	4 1/2
213TC	3 1/2	5 1/2	4 1/4	5 1/4
215TC	3 1/2	7	4 1/4	5 1/4
254TC	4 1/4	8 1/4	5	6 1/4
256TC	4 1/4	10	5	6 1/4
284TC	4 3/4	9 1/2	5 1/2	7
286TC	4 3/4	11	5 1/2	7
324TC	5 1/4	10 1/2	6 1/4	8
326TC	5 1/4	12	6 1/4	8

Dimensions for Adapter Mounting 2C2B-6C2B & 4312-4316 & 4332-4336 pumps to NEMA C Frame Motors

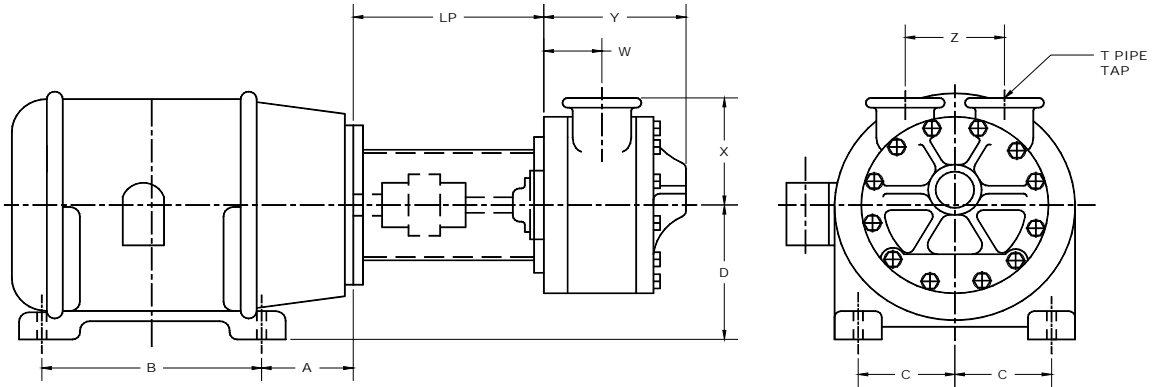

Pump Model	Motor Frame Size	LP	Adapter	Adapter Kit
2C2B / 4312 / 4332	56C	7 15/16	2C1B51-56	2C1B534-56
	143TC, 145TC	7 15/16	2C1B51-56	2C1B534-143
	182TC, 184TC	8 9/16	2C1B51-182	2C1B534-182
3C2B / 4313 / 4333 4C2B / 4314 / 4334	56C	8 5/16	3C2B51-56	3C2B534-56
	143TC, 145TC	8 5/16	3C2B51-56	3C2B534-143
	182TC, 184TC	8 15/16	3C2B51-182	3C2B534-182
	213TC, 215TC	9 11/16	3C2B51-213	3C2B534-213
5C2B / 4315 / 4335 6C2B / 4316 / 4336	182TC, 184TC	9 3/4	5C2B51-182	5C2B534-182
	213TC, 215TC	10 1/2	5C2B51-213	5C2B534-213
	254TC, 256TC	11 3/16	5C2B51-254	5C2B534-254
	284TC, 286TC	11 15/16	5C2B51-284	5C2B534-284
	324TC, 326TC	12 11/16	5C2B51-324	5C2B534-324

Pump Model	T	W	X	Y	Y DIM WITH RELIEF VALVE	Z
2C2B / 4312 / 4332	1" NPT	1	3 11/16	2 1/2	3 19/32	3 1/8
3C2B / 4313 / 4333	1 1/4" NPT	1 3/8	4 7/8	3 3/32	4 3/32	4 1/8
4C2B / 4314 / 4334	1 1/2" NPT	1 15/32	4 1/8	4 13/32	5 13/32	3 3/4
5C2B / 4315 / 4335	1 1/2" NPT	2 3/8	5	5 11/16	6 15/16	4 3/4
6C2B / 4316 / 4336	2" NPT	2 5/8	4 3/4	6 1/8	7 3/8	4 3/4

Motor Frame	A	B	C	D
56C	2 3/4	3	2 7/16	3 1/2
143TC	2 1/4	4	2 3/4	3 1/2
145TC	2 1/4	5	2 3/4	3 1/2
182TC	2 3/4	4 1/2	3 3/4	4 1/2
184TC	2 3/4	5 1/2	3 3/4	4 1/2
213TC	3 1/2	5 1/2	4 1/4	5 1/4
215TC	3 1/2	7	4 1/4	5 1/4
254TC	4 1/4	8 1/4	5	6 1/4
256TC	4 1/4	10	5	6 1/4
284TC	4 3/4	9 1/2	5 1/2	7
286TC	4 3/4	11	5 1/2	7
324TC	5 1/4	10 1/2	6 1/4	8
326TC	5 1/4	12	6 1/4	8

Dimensions for Adapter Mounting 2CK1B-6CK1B pumps to NEMA C Frame Motors

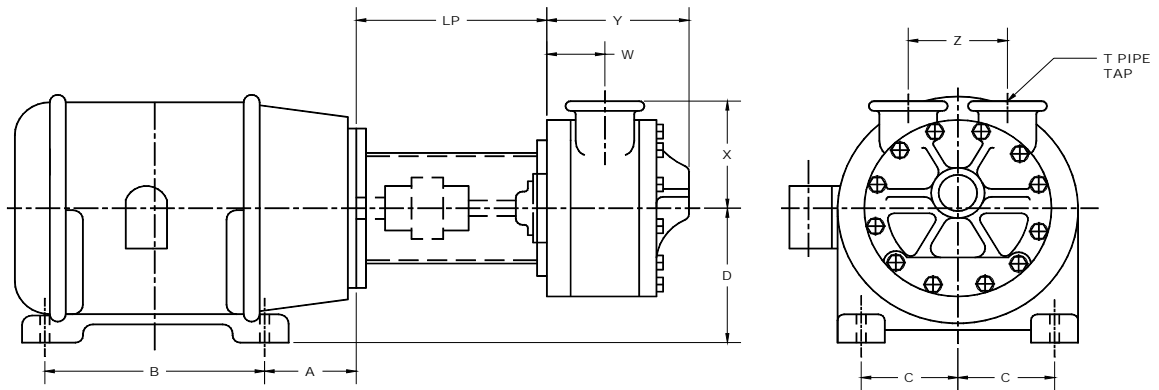

Pump Model	Motor Frame Size	LP	Adapter	Adapter Kit
2CK1B	56C	7 13/16	2CK1B51-56	2CK1B534-56
	143TC, 145TC	7 13/16	2CK1B51-56	2CK1B534-56
	182TC, 184TC	8 7/16	2CK1B51-182	2CK1B534-182
3CK1B	56C	8 5/8	3CK1B51-56	3CK1B534-56
	143TC, 145TC	8 5/8	3CK1B51-56	3CK1B534-56
	182TC, 184TC	9 1/8	3CK1B51-182	3CK1B534-182
4CK1B	213TC, 215TC	10 1/4	3CK1B51-213	3CK1B534-213
	254TC, 256TC	11 1/16	5CK1B51-213	5CK1B534-213
5CK1B 6CK1B	182TC, 184TC	10 5/16	5CK1B51-182	5CK1B534-182
	213TC, 215TC	11 1/16	5CK1B51-213	5CK1B534-213
	254TC, 256TC	11 7/8	5CK1B51-254	5CK1B534-254
	284TC, 286TC	12 7/8	5CK1B51-284	5CK1B534-284
	324TC, 326TC	13 3/4	5CK1B51-324	5CK1B534-324

Pump Model	T	W	X	Y	Y DIM WITH RELIEF VALVE	Z
2CK1B	1/2" NPT	7/8	2 3/4	2 5/8	3 23/32	2 3/4
3CK1B	3/4" NPT	7/8	3 1/2	2 29/32	3 29/32	3 1/2
4CK1B	1" NPT	1 3/16	3 3/4	3 19/32	4 19/32	3 3/4
5CK1B	1 1/4" NPT	1 1/2	4 3/4	5 1/16	6 5/16	4 3/4
6CK1B	2" NPT	1 3/4	4 3/4	5 9/16	6 13/16	4 3/4

Motor Frame	A	B	C	D
56C	2 3/4	3	2 7/16	3 1/2
143TC	2 1/4	4	2 3/4	3 1/2
145TC	2 1/4	5	2 3/4	3 1/2
182TC	2 3/4	4 1/2	3 3/4	4 1/2
184TC	2 3/4	5 1/2	3 3/4	4 1/2
213TC	3 1/2	5 1/2	4 1/4	5 1/4
215TC	3 1/2	7	4 1/4	5 1/4
254TC	4 1/4	8 1/4	5	6 1/4
256TC	4 1/4	10	5	6 1/4
284TC	4 3/4	9 1/2	5 1/2	7
286TC	4 3/4	11	5 1/2	7
324TC	5 1/4	10 1/2	6 1/4	8
326TC	5 1/4	12	6 1/4	8

Dimensions for C Series Mounting Feet (2C81, 3C81, 3CK81 & 5C81)

2C81 (FOR 2C SIZE PUMPS)

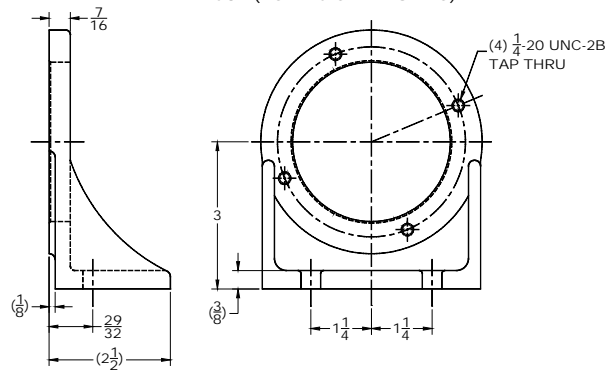

3C81 (FOR 3 & 4C SIZE PUMPS)

3CK81 (FOR 2, 3 & 4CK1B SIZE PUMPS ONLY)

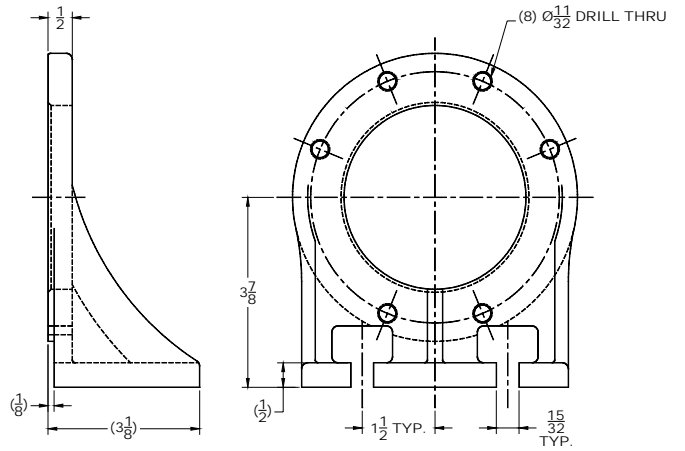
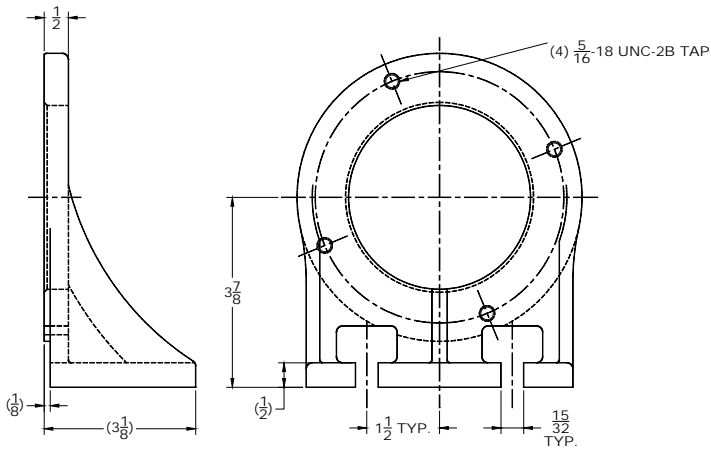

5C81 (FOR 5 & 6C SIZE PUMPS)

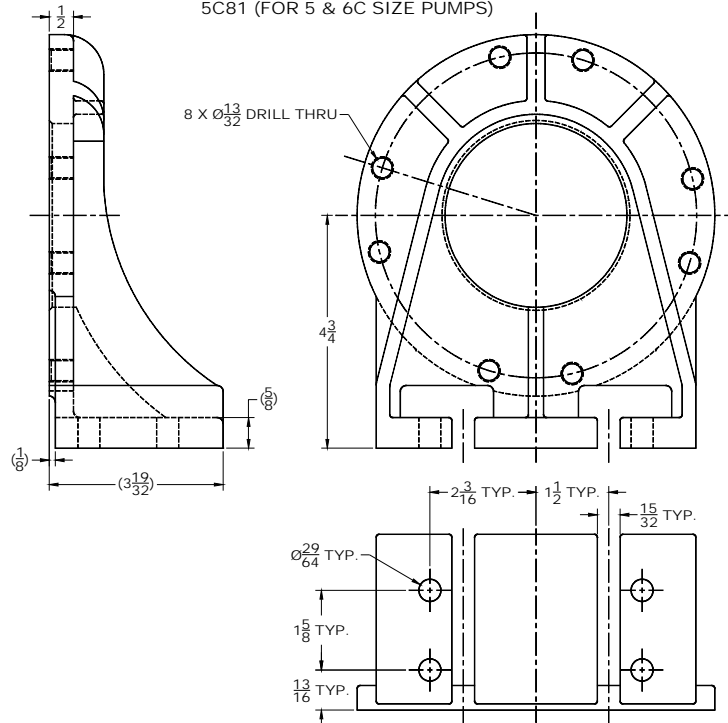

4000/C Cross Reference List

<u>4210 Pumps</u>	<u>C2G Pump</u>	<u>4210 Series Additional Features</u>
4212	2C2G	- Carbon bracket bushing Vs. bronze - Steel idler gear Vs. powdered metal - Carbon Idler bushing Vs. none
4213	3C2G	- Carbon bracket bushing Vs. bronze - Steel idler gear Vs. powdered metal - Carbon Idler bushing Vs. bronze
4214	4C2G	Same as above
4215	5C2G	Same as above
4216	6C2G	Same as above

Options: -V is available on both pumps.

Note: The Tuthill reversing feature is not available on 4000 pumps.

<u>4230 Pumps</u>	<u>C2G Pump</u>	<u>4230 Series Additional Features</u>
4232	2C2G	- Ceramic bracket bushing Vs. bronze - Steel idler gear Vs. powdered metal - Carbon idler bushing Vs. none - Tutrided cast iron cover Vs. cast iron cover - Induction hardened steel rotor Vs. steel rotor
4233	3C2G	- Ceramic bracket bushing Vs. bronze - Steel idler gear Vs. powdered metal - Carbon idler bushing Vs. bronze - Tutrided cast iron cover Vs. cast iron cover - Induction hardened steel rotor Vs. steel rotor
4234	4C2G	Same as above
4235	5C2G	Same as above
4236	6C2G	Same as above

Options: -V is available on both pumps.

Note: The Tuthill reversing feature is not available on 4000 pumps.

<u>4310 Pumps</u>	<u>C2B Pump</u>	<u>4310 Series Additional Features</u>
4312	2C2B	- Carbon bracket bushing Vs. bronze - Steel idler gear Vs. powdered metal - Carbon Idler bushing Vs. none
4313	3C2B	- Carbon bracket bushing Vs. bronze - Steel idler gear Vs. powdered metal - Carbon Idler bushing Vs. bronze
4314	4C2B	Same as above
4315	5C2B	Same as above
4316	6C2B	Same as above

Options: -V-5-6-7-8 and mounting feet 2C81, 3C81 & 5C81 are available on both pumps.

Note: The Tuthill reversing feature is not available on 4000 pumps.

4000/C Cross Reference List

<u>4330 Pumps</u>	<u>C2B Pump</u>	<u>4330 Series Additional Features</u>
4332	2C2B	<ul style="list-style-type: none"> - Ceramic bracket bushing Vs. bronze - Steel idler gear Vs. powdered metal - Carbon idler bushing Vs. none - Tutrided cast iron cover Vs. cast iron cover - Induction hardened steel rotor Vs. steel rotor
4333	3C2B	<ul style="list-style-type: none"> - Ceramic bracket bushing Vs. bronze - Steel idler gear Vs. powdered metal - Carbon idler bushing Vs. bronze - Tutrided cast iron cover Vs. cast iron cover - Induction hardened steel rotor Vs. steel rotor
4334	4C2B	Same as above
4335	5C2B	Same as above
4336	6C2B	Same as above

Options: -V-5-6-7-8 and mounting feet 2C81, 3C81 & 5C81 are available on both pumps.

Note: The Tuthill reversing feature is not available on 4000 pumps.

- 4210 and 4230 pumps have the same assembled dimensions as their C2G pump counterparts.

- 4310 pumps have the same assembled dimensions as their C2B pump counterparts.

4312-4316 Pump Mounting Dimensions

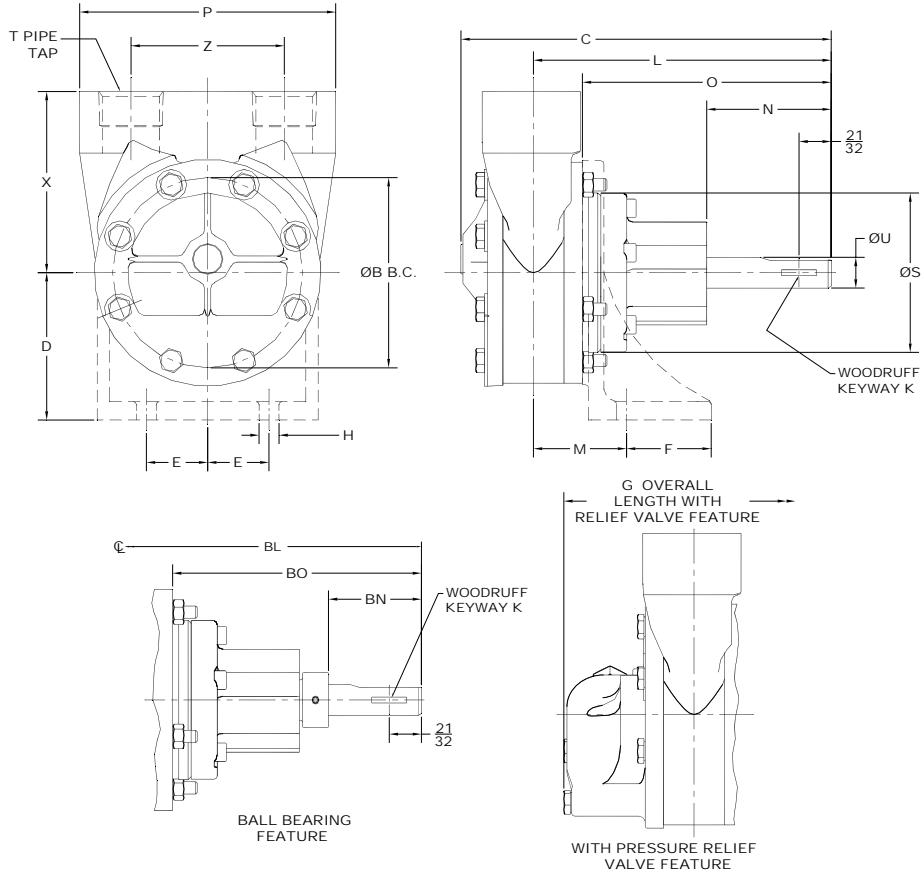

Model	C	G	D	E	F	H	K	L	M	N	O
4312	7 9/16	8 21/32	3	1 1/4	1 19/32	13/32	#406	6 1/16	1 29/32	2 17/32	5 1/16
4313	8 17/32	9 17/32	3 7/8	1 1/2	SLOT	15/32	#606	6 13/16	SLOT	2 1/2	5 7/16
4314	9 27/32	10 7/32	3 7/8	1 1/2	SLOT	15/32	#606	6 29/32	SLOT	2 1/2	5 7/16
4315	11 15/16	13 1/8	4 3/4	1 1/2	SLOT	15/32	#808	8 5/8	SLOT	3 13/32	6 1/4
4316	12 3/8	13 5/8	4 3/4	1 1/2	SLOT	15/32	#808	8 7/8	SLOT	3 13/32	6 1/4

Model	P	S	T	U	X	Z	BL	BN	BO
4312	5 7/32	3 1/4	1" NPT	5/8	3 11/16	3 1/8	6 1/16	1 27/32	5 1/16
4313	6 5/8	3 3/4	1 1/4" NPT	3/4	4 7/8	4 1/8	6 13/16	1 25/32	5 7/16
4314	6 1/2	3 3/4	1 1/2" NPT	3/4	4 1/8	3 3/4	6 29/32	1 25/32	5 7/16
4315	7 1/2	3 3/4	1 1/2" NPT	1	5	4 3/4	8 5/8	2 9/16	6 1/4
4316	8 1/8	3 3/4	2" NPT	1	4 3/4	4 3/4	8 7/8	2 9/16	6 1/4

4212-4216 & 4232-4236 Pump Mounting Dimensions

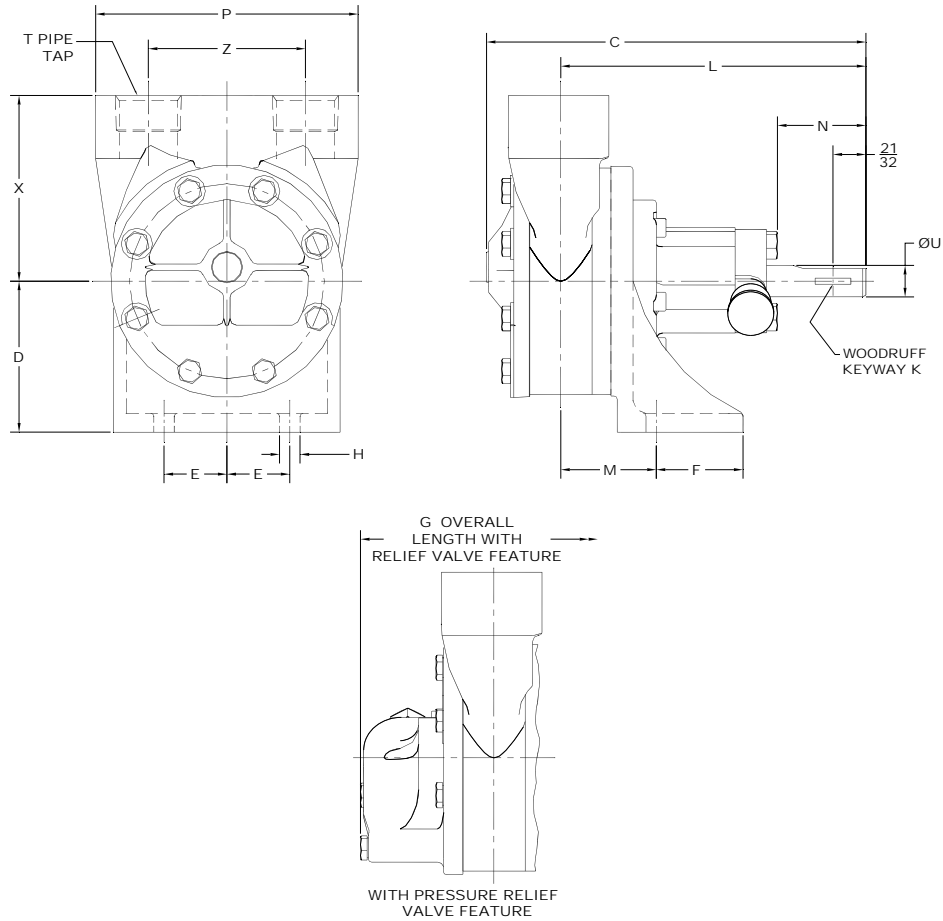

Model	C	G	D	E	F	H	K	L	M	N	P
4212	7 9/16	8 21/32	3	1 1/4	1 19/32	13/32	#606	6 1/16	1 29/32	1 11/16	5 7/32
4213	8 17/32	9 17/32	3 7/8	1 1/2	SLOT	15/32	#606	6 13/16	SLOT	1 13/16	6 5/8
4214	9 27/32	10 7/32	3 7/8	1 1/2	SLOT	15/32	#606	6 29/32	SLOT	1 13/16	6 1/2
4215	11 15/16	13 1/8	4 3/4	2 3/16	1 5/8	15/32	#808	8 5/8	3 3/16	2 21/32	7 1/2
4216	12 3/8	13 5/8	4 3/4	2 3/16	1 5/8	15/32	#808	8 7/8	3 7/16	2 21/32	8 1/8

Model	T	U	X	Z
4212	1" NPT	5/8	3 11/16	3 1/8
4213	1 1/4" NPT	3/4	4 7/8	4 1/8
4214	1 1/2" NPT	3/4	4 1/8	3 3/4
4215	1 1/2" NPT	1	5	4 3/4
4216	2" NPT	1	4 3/4	4 3/4

4332-4336 Pump Mounting Dimensions

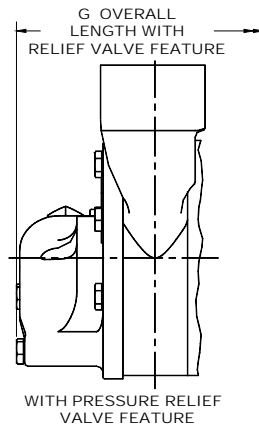
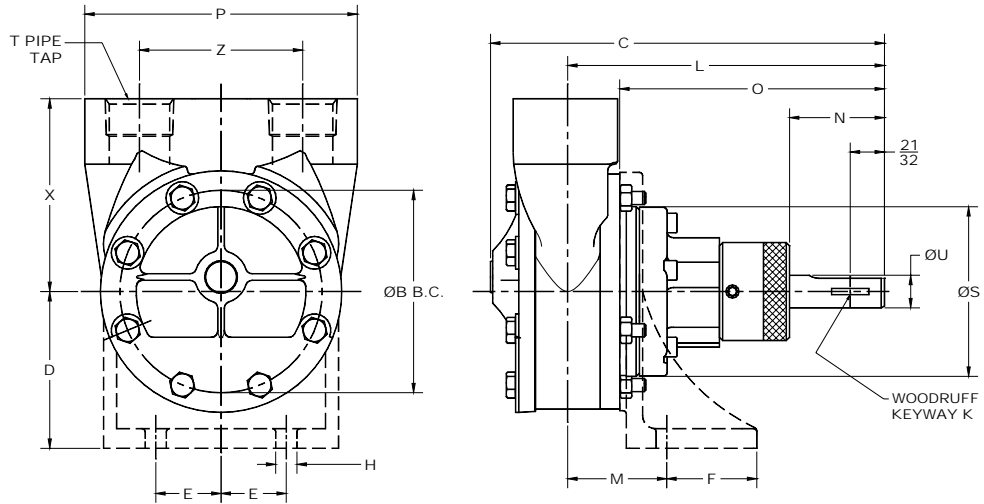

Model	C	G	D	E	F	H	K	L	M	N	O	P
4332	7 9/16	8 21/32	3	1 1/4	1 19/32	13/32	#406	6 1/16	1 29/32	1 13/16	5 1/16	5 7/32
4333	8 17/32	9 17/32	3 7/8	1 1/2	SLOT	15/32	#606	6 13/16	SLOT	1 25/32	5 7/16	6 5/8
4334	9 27/32	10 7/32	3 7/8	1 1/2	SLOT	15/32	#606	6 29/32	SLOT	1 25/32	5 7/16	6 1/2
4335	11 15/16	13 1/8	4 3/4	1 1/2	SLOT	15/32	#808	8 5/8	SLOT	2 11/16	6 1/4	7 1/2
4336	12 3/8	13 5/8	4 3/4	1 1/2	SLOT	15/32	#808	8 7/8	SLOT	2 11/16	6 1/4	8 1/8

Model	S	T	U	X	Z
4332	3 1/4	1" NPT	5/8	3 11/16	3 1/8
4333	3 3/4	1 1/4" NPT	3/4	4 7/8	4 1/8
4334	3 3/4	1 1/2" NPT	3/4	4 1/8	3 3/4
4335	3 3/4	1 1/2" NPT	1	5	4 3/4
4336	3 3/4	2" NPT	1	4 3/4	4 3/4

4200/4300 Pump Model Number System

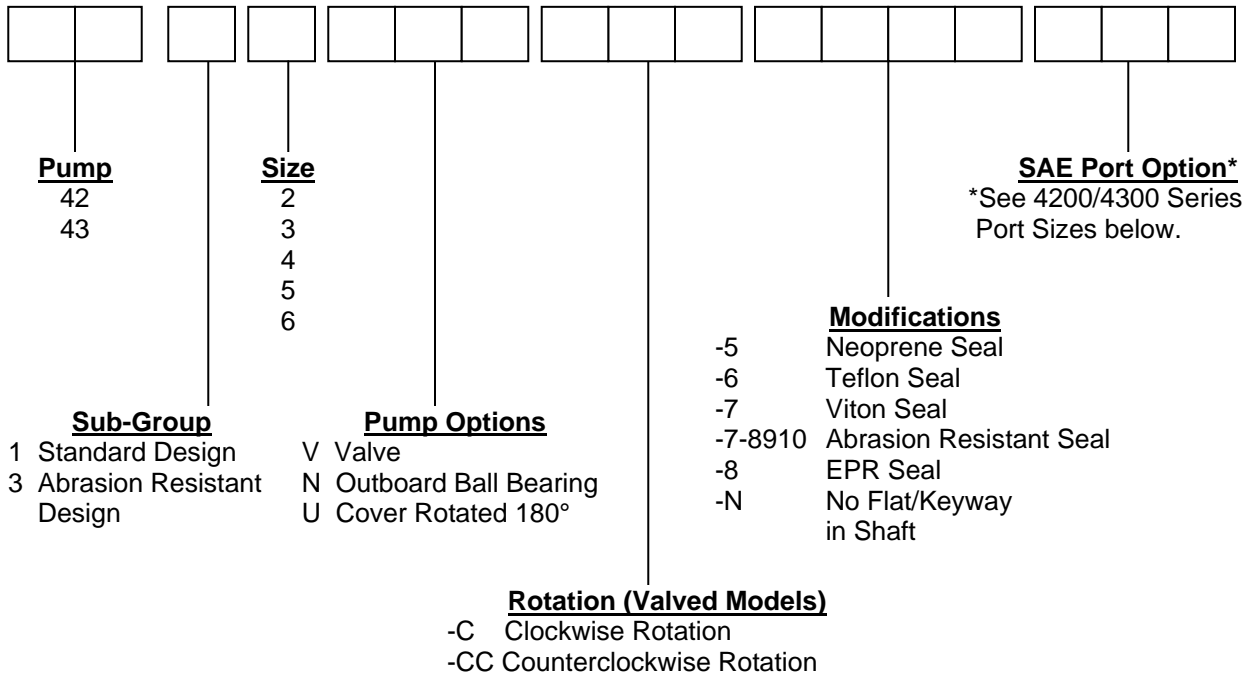

4200/4300 Series Port Sizes

Port		Pump Size				
Style	Size	2	3	4	5	6
NPT	1"	STD.	-	-	-	-
	1 1/4"	-	STD.	-	-	-
	1 1/2"	-	-	STD.	STD.	-
	2"	-	-	-	-	STD.
BSPP	1"	OPT.	-	-	-	-
	1 1/4"	-	OPT.	-	-	-
	1 1/2"	-	-	OPT.	OPT.	-
BSPT	1"	OPT.	-	-	-	-
	1 1/4"	-	OPT.	-	-	-
SAE	14	OPT.	-	-	-	-
	16	OPT.	OPT.	-	-	-
	20	-	OPT.	OPT.	-	-
	24	-	-	OPT.	OPT.	-
	32	-	-	-	-	OPT.

Model Number Location

Stamped on a metal tag on the cover

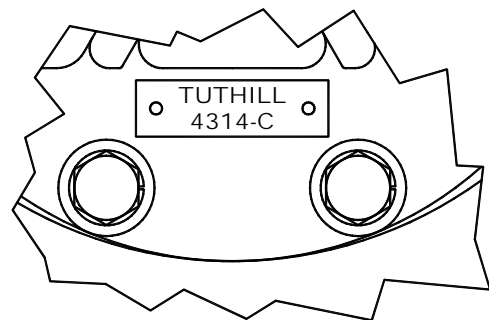

4200/4300 Pump Temperature Limits

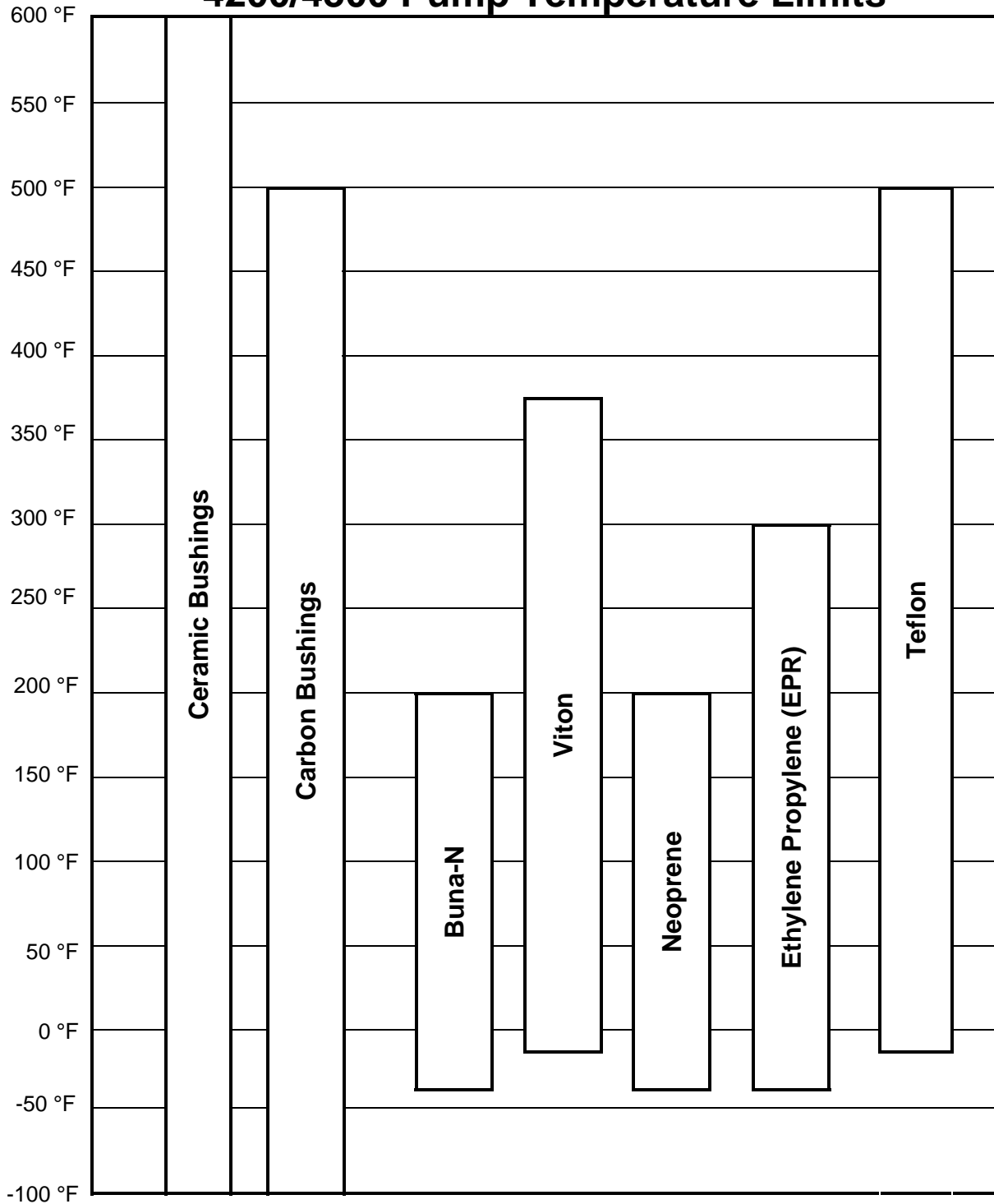

Notes:

1. A pump's performance is dependent on more than just the temperature ranges of the component materials.

4200/4300 Pump Materials of Construction

Part Name	Material	Standard	Comments	Availability
Housing	Cast Iron	ASTM A48 – 96a	Classes 25, 30, 35, or 40	Std.
Bracket	Cast Iron	ASTM A48 – 96a	Classes 25, 30, 35, or 40	Std.
Bracket Bushing	Carbon	Carbon Graphite Resin		Std.
	Ceramic	Alumina Ceramic, Diamonite	Std. on 4230 & 4330 Models	Opt.
Cover	Cast Iron	ASTM A48 – 96a	Classes 25, 30, 35, or 40	Std.
	Cast Iron	ASTM A48 – 96a	Heat Treated (Std. on 4230 & 4330 Models)	Opt.
Rotor	Steel	C1137 or C1141	Steel Forging	Std.
	Steel	C1137 or C1141	Heat Treated (Std. on 4230 & 4330 Models)	Opt.
Idler	Steel	C1117		Std.
Idler Pin	Steel	C1117	Heat Treated	Std.
Idler Bushing	Carbon	Carbon Graphite Resin		Std.
Seal Gland	Cast Iron	ASTM A48 – 96a	Classes 25, 30, 35, or 40	Std.
	DU Bushing		Only on 4310 models	
Adjustable Thrust Sleeve	Steel	AISI 1018	Only on 4330 Models	Std.
Packing Gland	Cast Iron	ASTM A48 – 96a	Only on 4210 & 4230 models	Std.
	Bronze	SAE 660		
O-Rings	Buna			Std.
	Viton			Opt.
	Neoprene			Opt.
	EPR			Opt.
	Teflon			Opt.

* Bronze idler bushing standard on 3-6 size pumps (2 size available with steel idler gear).

CC09 Pump/NEMA Motor Mounting Dimensions

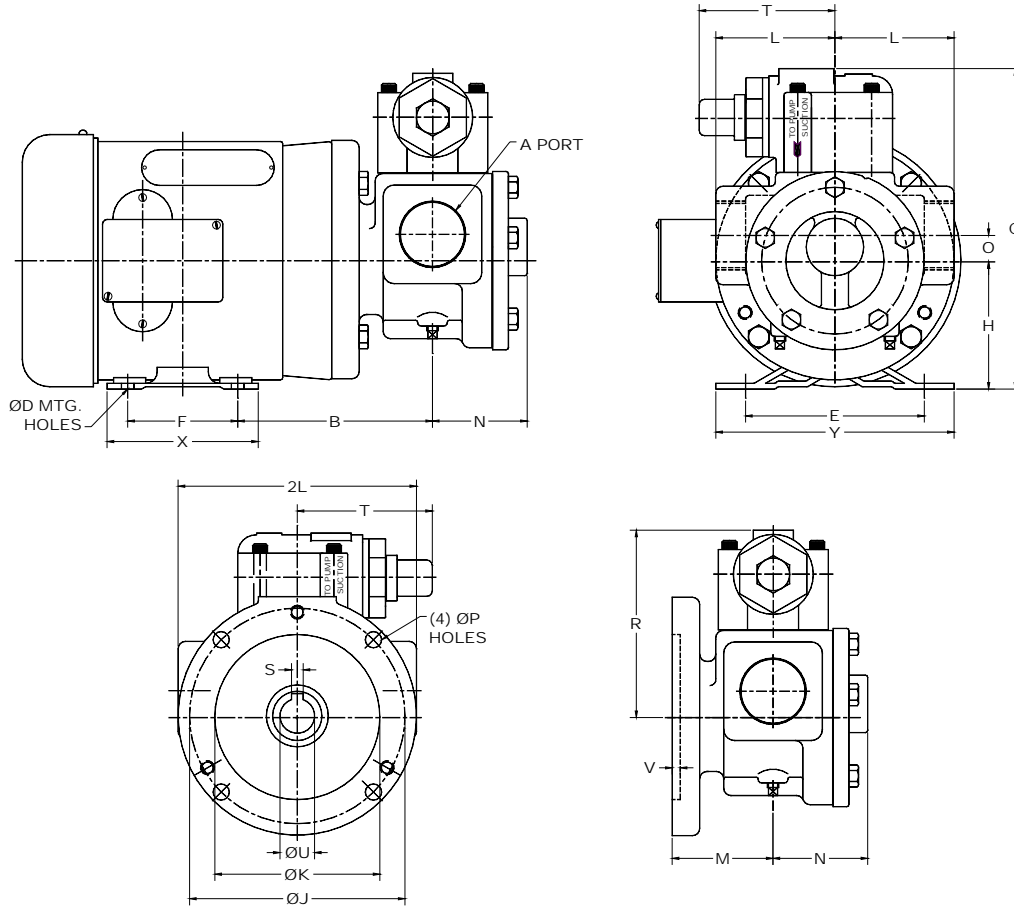

Motor Frame Size	A	B	C	D	E	F	H	J	K	L	M	N	O
56C	1" NPT or 1" BSP	5 25/64	8 5/16	11/32	4 7/8	3	3 1/2	5 7/8	4 1/2	2 1/2	2 53/64	1 31/64	17/32
143TC		5 5/64	8 5/16	11/32	5 1/2	4	3 1/2	5 7/8	4 1/2	2 1/2	2 53/64	1 31/64	17/32
145TC		5 5/64	8 5/16	11/32	5 1/2	5	3 1/2	5 7/8	4 1/2	2 1/2	2 53/64	1 31/64	17/32

Motor Frame Size	P	R	S	T	U	V	X	Y
56C	15/32	4 13/16	3/16	3 23/32	5/8	15/64	3 3/4	6 3/16
143TC	15/32	4 13/16	3/16	3 23/32	7/8	15/64	5	6 7/8
145TC	15/32	4 13/16	3/16	3 23/32	7/8	15/64	5	6 7/8

CC09 Pump/IEC Motor Mounting Dimensions

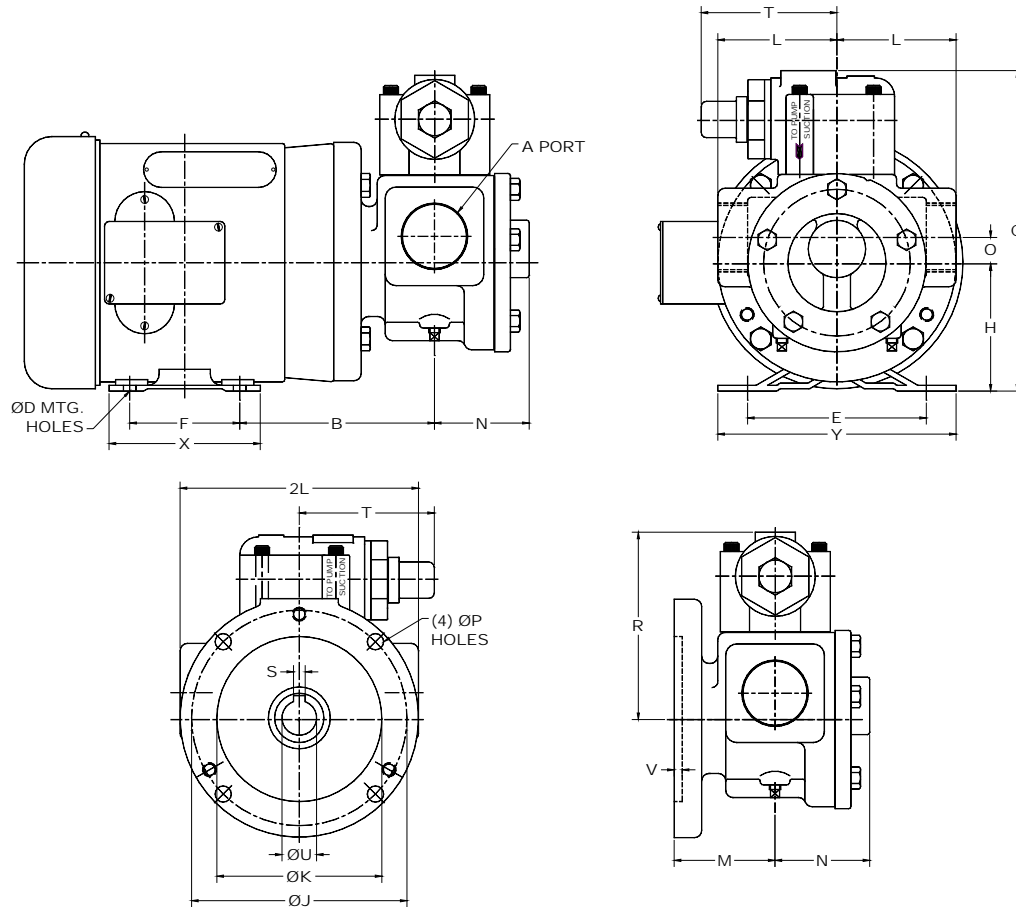

Motor Frame Size	A	B	C	D	E	F	H	J	K	L	M	N	O
IEC 71	1" BSPT	116.8	193.2	7	112	90	71	130	110	63.5	71.8	37.7	13.5
IEC 90		127.8	212.2	10	140	100 OR 125	90	115	95	63.5	71.8	37.7	13.5
IEC 100		134.8	222.2	12	160	112 OR 140	100	130	110	63.5	71.8	37.7	13.5
IEC 112		141.8	234.2	12	190	114 OR 140	112	130	110	63.5	71.8	37.7	13.5

Motor Frame Size	P	R	S	T	U	V	X	Y
IEC 71	10.3	122.2	5	94.5	14	6	115	140
IEC 90	10.3	122.2	8	94.5	24	6	150	170
IEC 100	10.3	122.2	8	94.5	28	6	175	195
IEC 112	10.3	122.2	8	94.5	28	6	175	224

Dimensions shown are in millimeters.

CC015, 020 & 030 Pump/NEMA Motor Mounting Dimensions

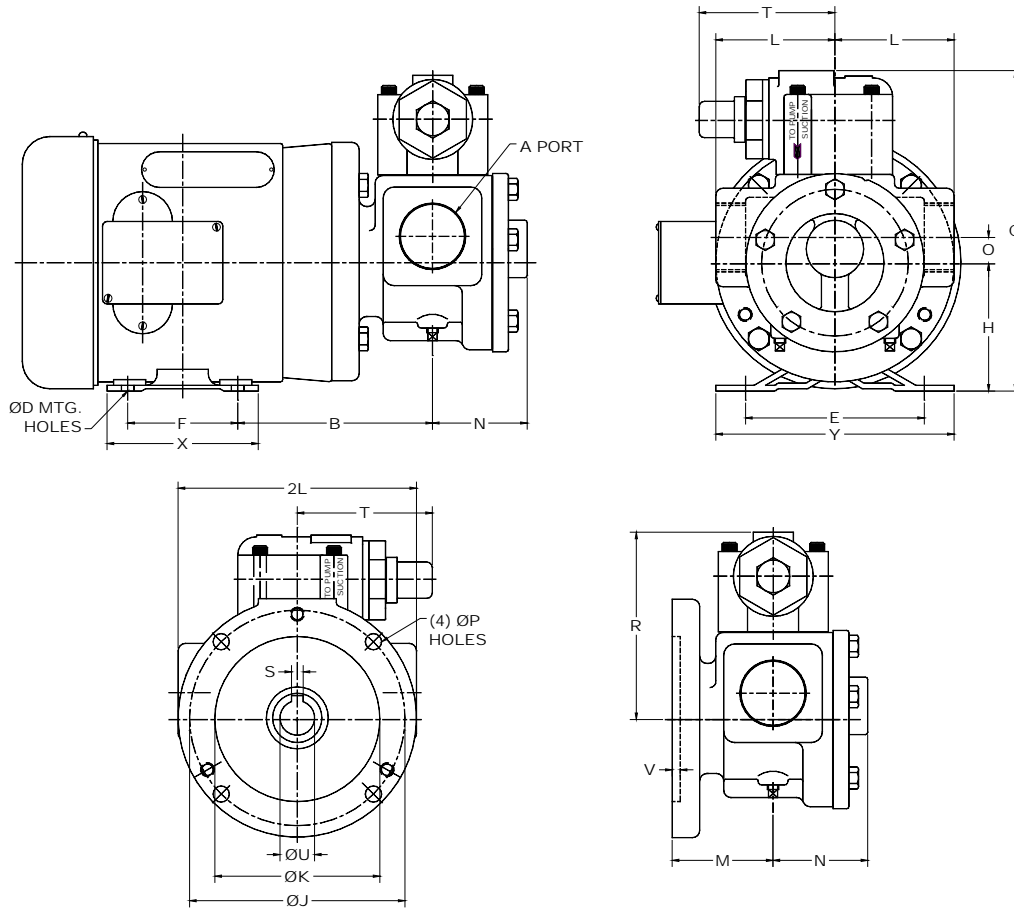

Motor Frame Size	A	B	C	D	E	F	H	J	K	L	M	N
56C	1 1/2" NPT or 1 1/2" BSP	5 23/64	8 49/64	11/32	4 7/8	3	3 1/2	5 7/8	4 1/2	3 1/4	2 47/64	2 23/32
143TC		5	8 49/64	11/32	5 1/2	4	3 1/2	5 7/8	4 1/2	3 1/4	2 47/64	2 23/32
145TC		5	8 49/64	11/32	5 1/2	5	3 1/2	5 7/8	4 1/2	3 1/4	2 47/64	2 23/32
182TC*		5 23/64	9 49/64	1/2	7 1/2	5 1/2	4 1/2	5 7/8	4 1/2	3 1/4	2 47/64	2 23/32
184TC*		5 23/64	9 49/64	1/2	7 1/2	5 1/2	4 1/2	5 7/8	4 1/2	3 1/4	2 47/64	2 23/32

Motor Frame Size	O	P	R	S	T	U	V	X	Y
56C	5/8	15/32	4 3/8	3/16	3 45/64	5/8	15/64	3 3/4	6 3/16
143TC	5/8	15/32	5 17/64	3/16	3 45/64	7/8	15/64	5	6 7/8
145TC	5/8	15/32	5 17/64	3/16	3 45/64	7/8	15/64	6	6 7/8
182TC*	5/8	15/32	5 17/64	3/16	3 45/64	7/8	15/64	6 23/32	9
184TC*	5/8	15/32	5 17/64	3/16	3 45/64	7/8	15/64	6 23/32	9

Note frame size when making motor selection.
 *Will require a special "C" motor flange and a 7/8" shaft.

CC015, 020 & 030 Pump/IEC Motor Mounting Dimensions

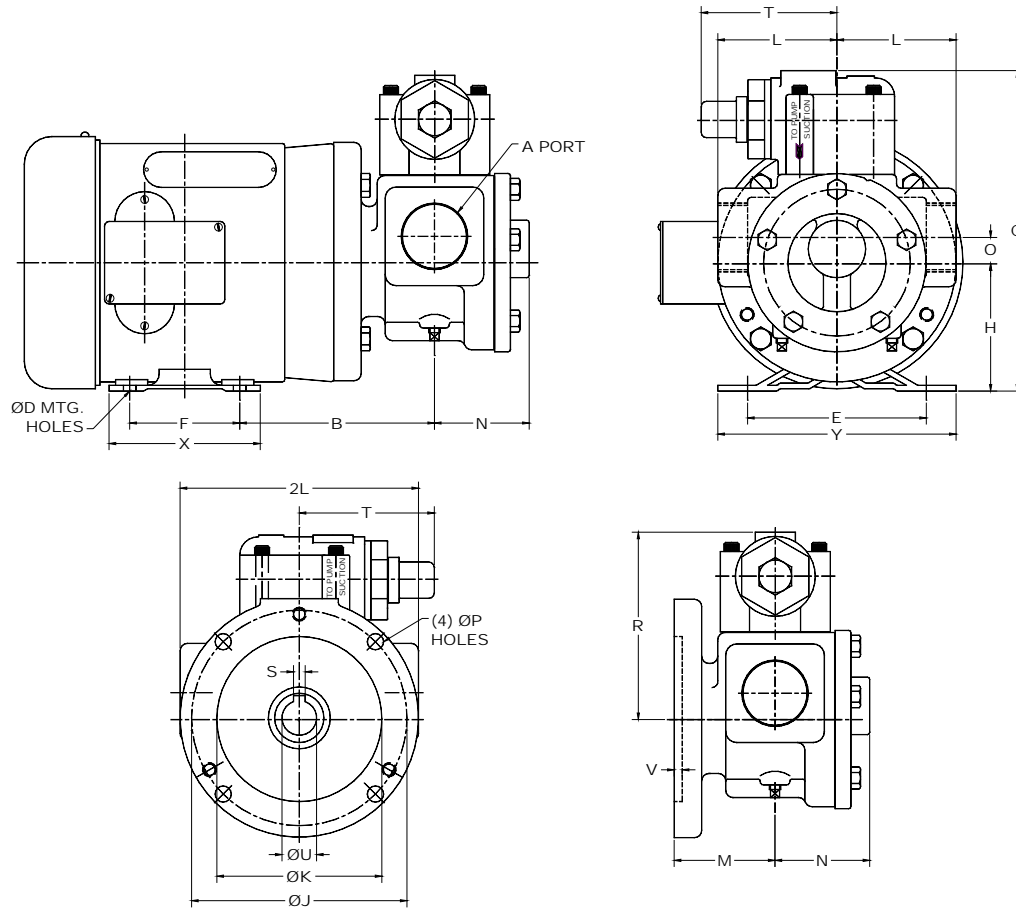

Motor Frame Size	A	B	C	D	E	F	H	J	K	L	M	N
IEC 71	1 1/2" BSPT	114.9	204.7	7	112	90	71	130	110	82.6	69.9	69
IEC 80		119.9	213.7	10	125	100	80	100	80	82.6	69.9	69
IEC 90		125.9	223.7	10	140	100 OR 125	90	115	95	82.6	69.9	69
IEC 100		132.9	233.7	12	160	112 OR 140	100	130	110	82.6	69.9	69
IEC 112		139.9	245.7	12	190	114 OR 140	112	130	110	82.6	69.9	69

Motor Frame Size	O	P	R	S	T	U	V	X	Y
IEC 71	15.88	10.3	133.7	5	94.1	14	6	115	140
IEC 80	15.88	7.1	133.7	6	94.1	19	6	130	155
IEC 90	15.88	10.3	133.7	8	94.1	24	6	150	170
IEC 100	15.88	10.3	133.7	8	94.1	28	6	175	195
IEC 112	15.88	10.3	133.7	8	94.1	28	6	175	224

Dimensions shown are in millimeters.

CC Pump Model Number System

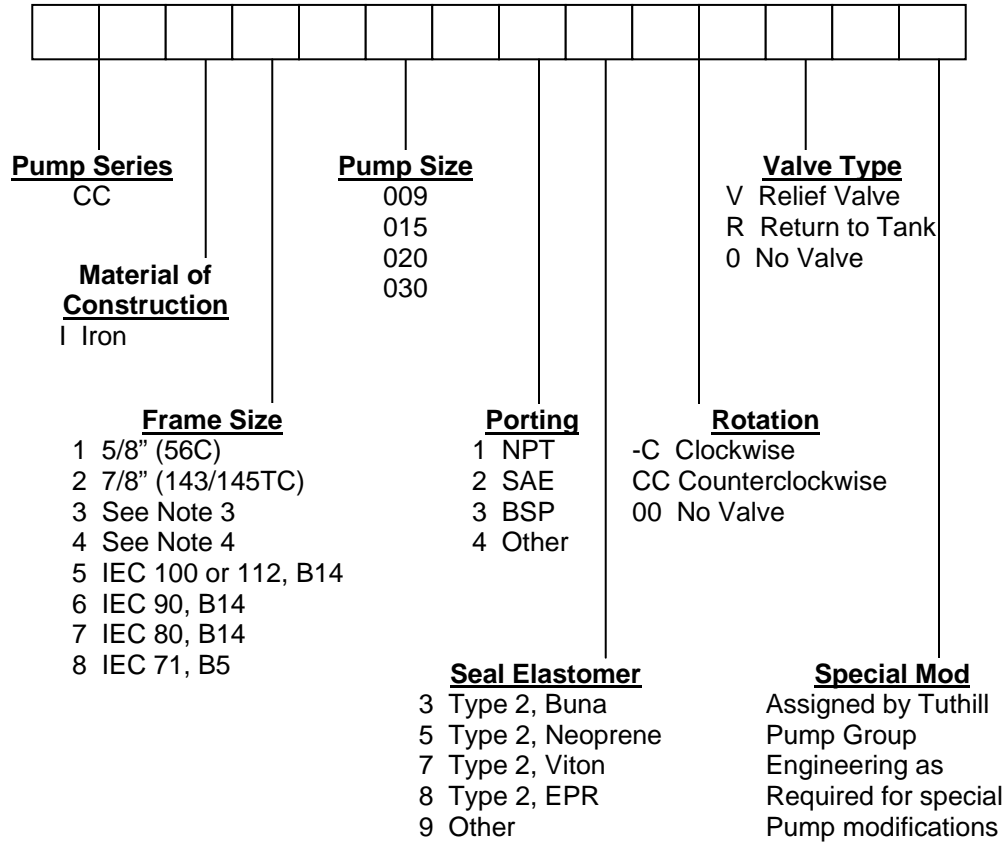

Notes:

- 1.) All IEC frames, except for IEC 71, reference a B14 Face type mounting. The IEC 71 frame mounting is a B5 flange type.
- 2.) The 009 size is not available in an IEC 80 frame size.
- 3.) Suitable for IEC 100/112, B14 with 19mm shaft.
- 4.) Suitable for IEC 100/112, B14 with 24mm shaft.

CC Pump Temperature Limits

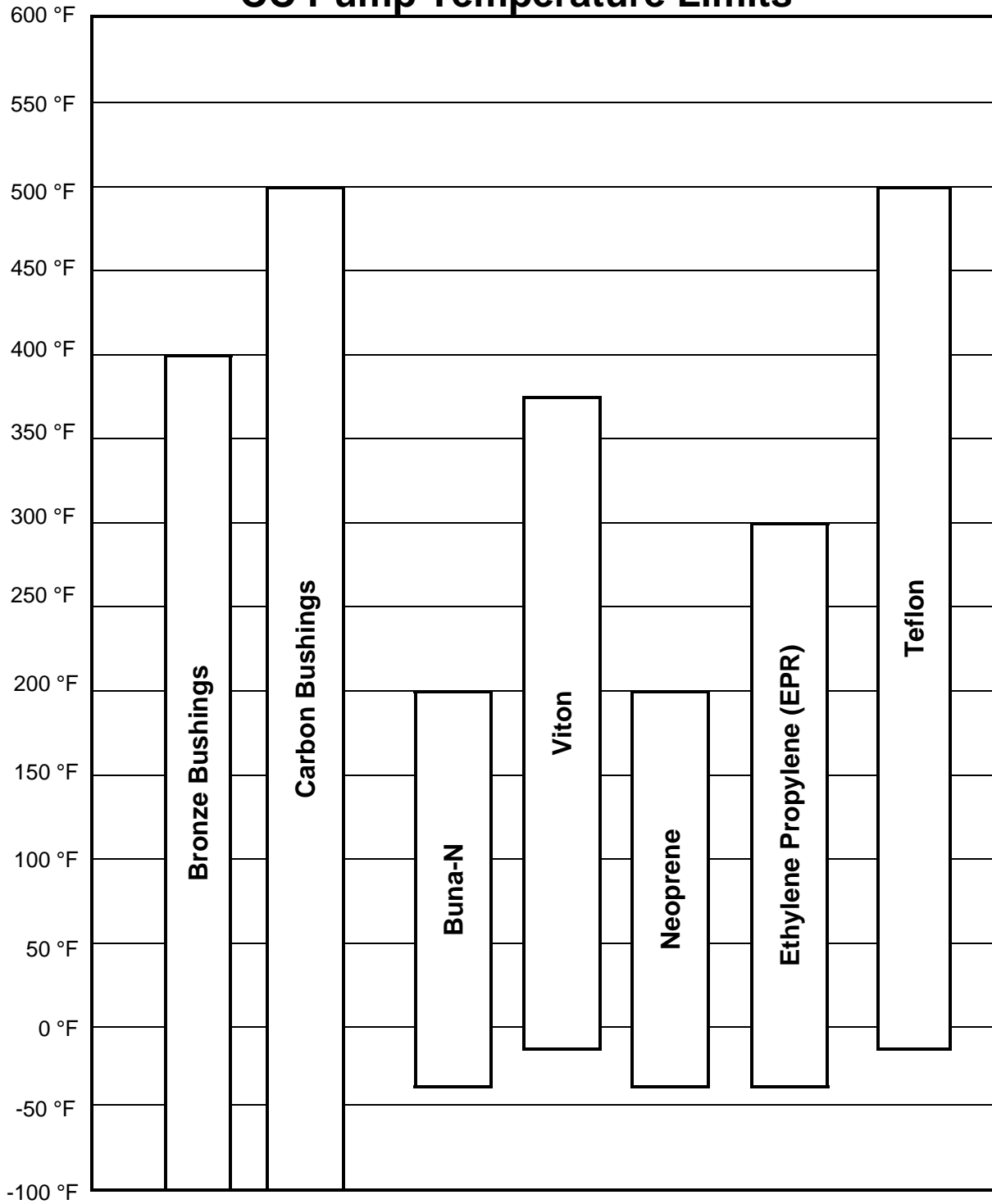

Notes:

A pump's performance is dependent on more than just the temperature ranges of the component materials.

CC Pump Materials of Construction

<i>Part Name</i>	<i>Material</i>	<i>Standard</i>	<i>Comments</i>	<i>Availability</i>
Housing	Cast Iron	ASTM A48 – 96a	Classes 25, 30, 35, or 40	Std.
Cover	Cast Iron	ASTM A48 – 96a	Classes 25, 30, 35, or 40	Std.
Rotor	Ductile Iron	ASTM A536	Ductile Iron Grade 80-55-06	Std.
Idler	Ductile Iron	ASTM A536	Ductile Iron Grade 80-55-06	Std.
Idler Pin	Steel	C1117	Heat Treated	Std.
Idler Bushing	Carbon	Carbon Graphite Resin		Std.
Relief Valve Body	Cast Iron	ASTM A48 – 96a	Classes 25, 30, 35, or 40	Std.
Relief Valve Block-Off Plate	Steel	ASTM A36		Std.
Gaskets	Standard	Oriented Polyester		Std.
	Standard	Garlock	Used for Relief Valve Pumps Only	Std.

CC Pump NPSH Data

NPSH Required for Tuthill "C" Series pumps 0-750 SSU

PUMP SERIES \ SPEED RPM		SPEED RPM					
		300	600	900	1200	1500	1800
CC009	FT.	1.4	1.9	3.1	4.5	6.4	9.1
CC015	FT.	1.5	2.1	3.3	5.0	7.0	9.8
CC020	FT.	1.6	2.3	3.6	5.5	7.7	10.4
CC030	FT.	1.7	2.6	4.1	6.6	9.1	11.8

Notes:

4. For liquid viscosity up to 750 SSU.
5. NPSHA (Net Positive Suction Head Available) must be greater than the NPSHR (Net Positive Suction Head Required) value provided in the table.
6. Values above are for feet of liquid with a Specific Gravity of 1.0.

Viscosity Correction Factor

	Viscosity (SSU)			
	1000	1500	2000	2500
Correction Factor	1.15	1.20	1.25	1.30