

easy mover[®]

The Original

One person can move up to 100 tons!

Pneumatic motor guarantees very high force.



easy
mover[®]

**All Easy Mover machines are manufactured and constructed in Sweden.
The Easy Mover was universally Patented in 1982 by REJMYRE MASKIN AB.**

- Designed for One-Person Operation on objects weighing up to 100 tons
- Pneumatically driven – Economical to operate – Quiet
- Smooth, Variable speed adjustment for precise operator control
- Environmentally safe – Non polluting
- Compact and lightweight
- Rugged, heavy-duty construction
- Operates at speeds up to 82 feet per minute
- Delivers an applied force up to 4000 lbs on any dry rolling surface
- Increases productivity – Reduces labor costs
- Increases Employee Safety – Prevent Injuries
- Offers an alternative to automated conveying
- Models for special applications are available

The Original Easy Mover. World Leader in Material Handling for over 20 Years



Rollers

Moves circular objects with a diameter of at least 24 inches. For example paper rolls, vehicles and cable reels.



The Easy Mover technique is based on a simple single hand operated equipment, which handles heavy loads/objects by using the weight of the moved object. The Easy Mover is pneumatic, which brings a smooth variable adjustment making it virtually impossible to overload. The Easy Mover is also non-polluting – quiet – clean – easy to operate and easy to install. The standard models are found here.

easy mover[®] Rollers

Model	Application	Capacity	Unit Weight	Force Applied	Maximum Speed	Air Pressure	Air Volume
P 350B	Paper rolls	< 10 ton	30 lbs	660 lbs	75 ft/min	85 psi	23 cfm
P 1250B	Paper rolls	< 20 ton	43 lbs	2640 lbs	82 ft/min	85 psi	44 cfm
V 350B	Vehicles	< 15 ton	30 lbs	660 lbs	75 ft/min	85 psi	23 cfm
V 1250B	Vehicles	< 25 ton	43 lbs	2640 lbs	82 ft/min	85 psi	44 cfm
F 1500A	Aircraft	< 25 ton	41 lbs	3300 lbs	56 ft/min	85 psi	44 cfm
C 1500A	Cable	< 50 ton	51 lbs	3300 lbs	49 ft/min	85 psi	44 cfm
CF 1500A	Cable	< 50 ton	56 lbs	3300 lbs	49 ft/min	85 psi	44 cfm

All machines can be customized to suit your requirements. Send us the type of application you need, and we will endeavour to help!

Widths, gearing, pickup and anchorage points are available in different designs.

The 1250 and 1500 machines can be equipped with a heavy duty motor with 33% higher torque.

easy mover[®] *The Original*

Easy Mover pushers are ideal for moving machines, truck and bus chassis or any type of fixtures on wheels or casters.

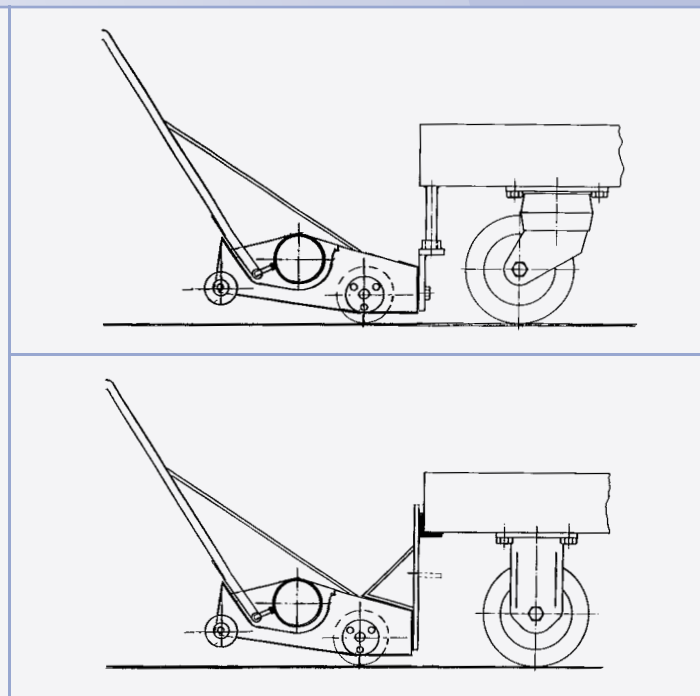
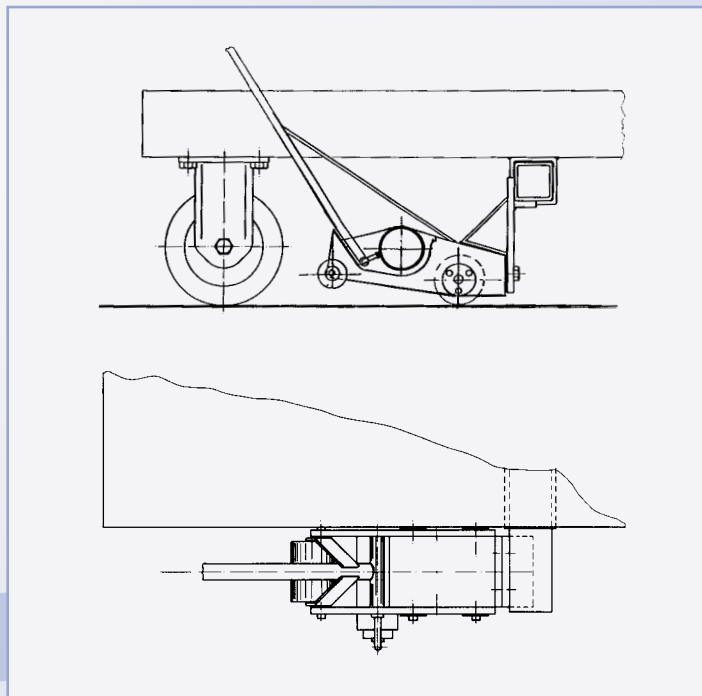

easy mover[®] Pushers

Model	Application	Capacity	Unit Weight	Force Applied	Maximum Speed	Air Pressure	Air Volume
A 550	Wagons	< 15 ton	38 lbs	660 lbs	75 ft/min	85 psi	23 cfm
A 1240	Wagons	< 30 ton	43 lbs	2640 lbs	82 ft/min	85 psi	44 cfm
AR 550*	Wagons	< 15 ton	38 lbs	1100 lbs	65 ft/min	85 psi	36 cfm
AR 1240*	Wagons	< 25 ton	43 lbs	1980 lbs	56 ft/min	85 psi	44 cfm

* Reversible

All machines can be customized to suit your requirements. Send us the type of application you need, and we will endeavour to help!

Widths, gearing, pickup and anchorage points are available in different designs.

easymover@sbcglobal.net
www.easymoverusa.com

easy mover[®] *The Original*

The ARL model Easy Mover, has a forward and reverse movement, with dual revolving wheels to provide easy steering, to enable versatile movement of fixtures, machines and wagons.

The Easy Mover has a unique pneumatic bellows anchorage point system for easy adjustable work load coupling.



easy mover[®] ARL 500A and ARL 1200A are convenient to use when moving heavy machinery, fixtures, carts, even end-products.

easy mover[®] ARL 500A and ARL 1200A are versatile enough for manufacturing, maintenance, processing or service environment.

PUSHARM SOCKET

accepts various male interfacings (ball, pin, rod).

AIR BELLOWS

inflates to link load to mover; downward pressure onto drive roller.

easy mover[®] Push, pull & maneuver

Model	Application	Capacity	Unit Weight	Force Applied	Maximum Speed	Air Pressure	Air Volume
ARL 500A*	Wagons	< 15 ton	69 lbs	1100 lbs	65 ft/min	85 psi	36 cfm
ARL 1200A*	Wagons	< 25 ton	99 lbs	1980 lbs	56 ft/min	85 psi	44 cfm

* Reversible + lift

Manufacturer

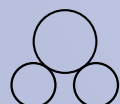

Rejmyre Maskin AB
SWEDEN

Tel +46 151 210 25 Fax +46 151 212 02

Brenäsvägen 4, SE-610 14 Rejmyre
info@rejmyremaskin.se www.easymover.se

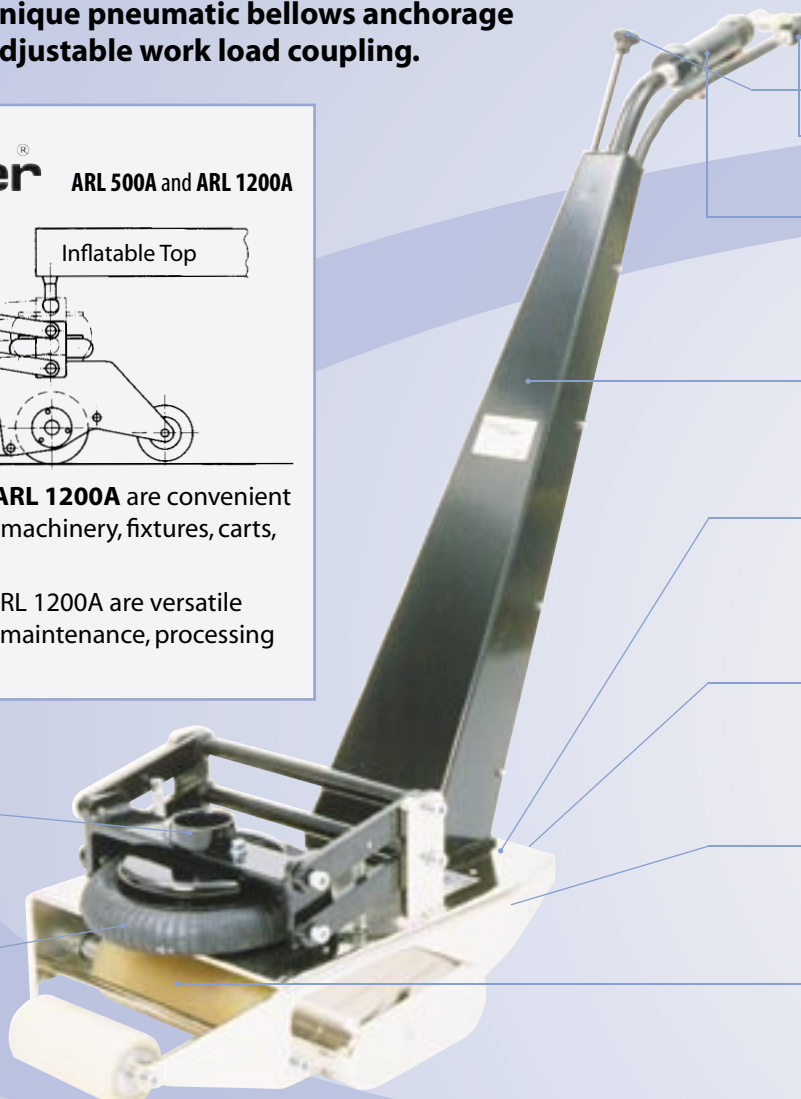

DRIVE DIRECTION CONTROL

AIR BELLOWS

Up and down

AIR VALVE

provides smooth, variable speed adjustment for precise operator control.

HANDLE HOUSING

safely shields air supply lines and drive direction control.

SUPERSTRUCTURE

is durable, corrosion-resistant Nickel plated steel.

DUAL REVOLVING WHEELS

of durable phenolic material provide easy steering for versatile movements of loads.

AIR MOTOR

High torque forward and reverse movement.

DRIVE ROLLER

features polyurethane material for optimum traction, excellent durability and easier steering.

Factory Sales and Service Center

Easy Mover, Inc

1715B Little Orchard Street
San José, CALIFORNIA 95125-1038
(408)289-8222 (408)885-9062 (fax)
easymover@sbcglobal.net (e-mail)
www.easymoverusa.com (web site)