

BARUFFALDI

MACHINE TOOL COMPONENTS

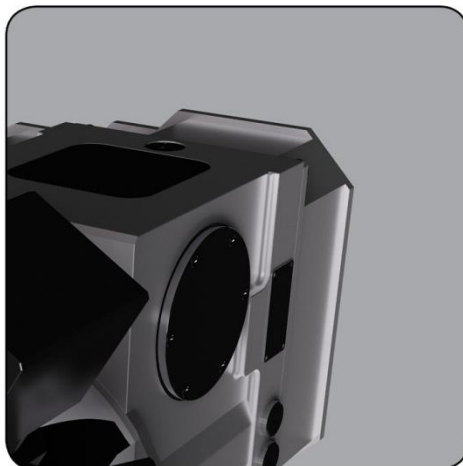

Gearboxes

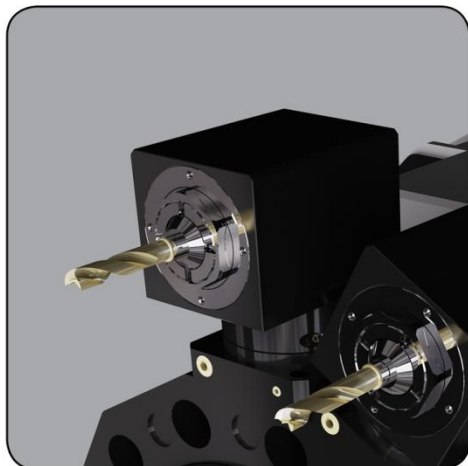
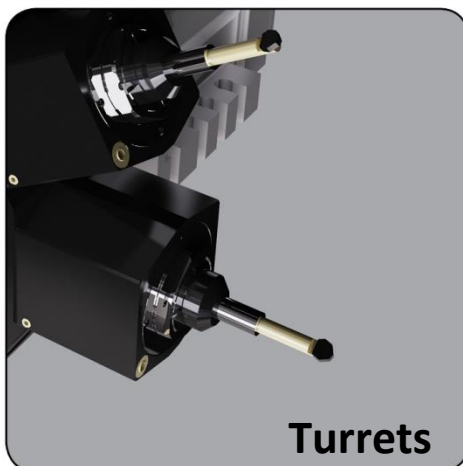

Turrets

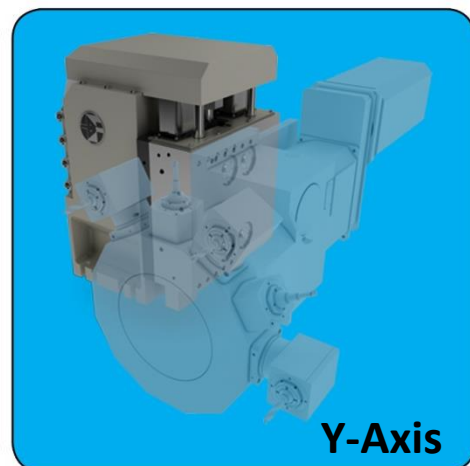

Y-Axis



Rotary Tools



Tool Discs

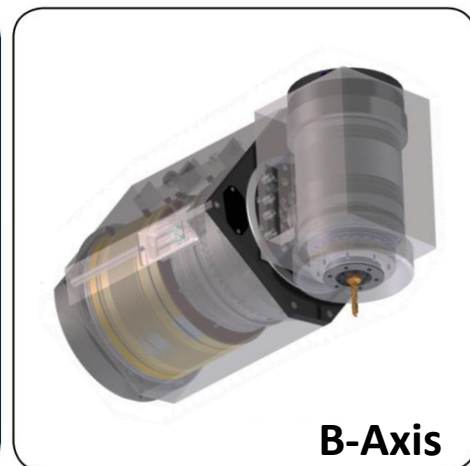

B-Axis

Quick Reference Catalog

WWW.BARUFFALDI.IT

DMLieferant Tel.: +7 (495) 990-25-55 www.dmliefer.ru

SERVO MOTOR TURRETS

TB Servo Turret



TB-type turrets rotate thanks to a **BRUSHLESS SERVO MOTOR** controlled by a **SERVO DRIVE**. A pneumatic or hydraulic piston locks/unlocks the unit. High rigidity, very accurate positioning and very high rotating speeds.

The turrets are available with several type of Tool Disc: VDI (standard), BMT, Polygonal open slot type, Capto and other special Discs.

Main characteristics:

- Disc rotation thanks to a **Servo Motor** controlled by a **Servo Drive**
- Very high indexing speed
- Locking and unlocking without axial movement
- Bi-directional rotation
- Absolute positioning
- Hydraulic or pneumatic locking/unlocking systems
- **Coolant pressure** through the turret up to **70 Bar**

Size	TB100	TB120	TB160	TB200	TB250	TB320	TB400	TB500	
N° of divisions	8-12-16			8 - 12 - 16 - 24					
Max Moment of Inertia	Kgm ²	0,25	0,15±0,18	0,15±0,18	0,4±8	0,4±8	0,7±40	20±100	100
Max Tangential Torque	Nm	450	1100	1900	4000	7500	16000	26000	75000
Max Overturning Torque (pressing)	Nm	400	1200	2100	6000	12000	25000	41400	50000
Max Lifting Torque (lifting)	Nm	150	700	1600	3500	6500	13000	20000	25000
Positioning Accuracy	Deg	±4" Deg.							
Accuracy of Repeatability	Deg	±1,6" Deg.							
Locking System	PN	•	•	•	•	•	•	•	•
	HYD		•	•	•	•	•	•	•
Locking/Unlocking: Pneumatic Pressure		5±1 Bar							
Locking/Unlocking: Hydraulic Pressure		30±3 Bar							
Coolant pressure (standard)		40 Bar							
Coolant pressure (special)		70 Bar							

TBMA (With Axial Driven Tools)

TBMA-type turrets, with **axial driven tools**. Discs according to ISO 10889 (ex DIN 69880) norms can be used. Compact overall dimensions of the driven tool system, very high rotating tools speed, double sensor switches for the engagement control, high rigidity and even higher performances due to the new design.

Main characteristics:

- High Speed of the driven tool system up to 6000rpm
- **Double proximity switch** for the tool engagement control
- Suitable for tooling/coupling: Baruffaldi (standard), DIN 5480 and DIN1809
- **7 turrets sizes**, many different possibilities and special applications
- Easy maintenance
- Possibility for **forced lubrication** in order to increase the **working time (100%)** and the **speed (8000rpm)**



Size	TBMA100	TBMA120	TBMA160	TBMA200	TBMA250	TBMA320	TBMA400	
VDI	16-20	20-30	30-40	40-50	50	60	60-80	
Max Speed	rpm	6000	6000	6000	5000	5000	3000	3000
Max Motor Torque	Nm	10	16	20	50	55	100	130
Max Power	Kw	3	5	6	9	10	15	19
Ratio		1:1	1:1	1:1	1:1	1:1	1:1	1:1
		-	-	1:1,25	1:1,315	1:1,52	1:1,45	1:1,85
Locking System	PN	•	•	•	•	•	•	•
	HYD		•	•	•	•	•	•
Live Tooling System	Baruffaldi	Baruffaldi	Baruffaldi	Baruffaldi	Baruffaldi	Baruffaldi	Baruffaldi	Baruffaldi
	-	DIN 1809	DIN 1809	DIN 1809	DIN 1809	-	-	-
	-	DIN 5480	DIN 5480	DIN 5480	DIN 5480	-	-	-

This data sheet show the characteristic of the Driven Tool Unit, for the turret see the TB's data sheet.

TBMR - VDI Type (With Radial Driven Tools)



TBMR-type turrets, with **radial driven tools**. The tools are located on discs with radial seats as per ISO 10889 (ex DIN 69880) norms. High speed, automatic engagement and disengagement of the rotating tool during turret indexing cycle, short or extended neck useful for back machining operations, strong housing and high flexibility.

Main characteristics:

- Double proximity switch for the tool engagement control
- High rigidity, due to the new design
- Wide range 160-200-250-320
- Possibility to use 8-12-16-24 position discs
- Possibility to use VDI 30-40-50-60
- Suitable for tooling/coupling: Baruffaldi (standard) and DIN 5480
- Easy maintenance

Size		TBMR160	TBMR200	TBMR250	TBMR320
VDI		30	40-50	50	60
Max Speed	rpm	5000	4000	4000	3000
Max Motor Torque	Nm	20	50	55	100
Max Power	Kw	6	9	10	15
Ratio		1:1	1:1	1:1	1:1
Locking System	PN	•	•	•	
	HYD	•	•	•	•
Live Tooling System		Baruffaldi	Baruffaldi	Baruffaldi	Baruffaldi
		DIN 1809	DIN 1809	DIN 1809	-
		DIN 5480	DIN 5480	DIN 5480	DIN5480

This data sheet show the characteristic of the Driven Tool Unit, for the turret see the TB's data sheet.

TBMR - BMT Type (With Radial Driven Tools)

TBMR-type turrets, with **radial driven tools** according to **BMT (Base Mounted Tool Holder)** standard, for static and rotating tools. The rotating tool holders use a BMT clutch system. Ultra high speed, short or extended neck, useful for back machining operations, strong housing and high flexibility.

Main characteristics:

- **High Speed** of the driven system **up to 6000rpm**
- BMT coupling (Base Mounted Toolholder) 45-55-65-75-85
- High rigidity, due to the new design
- Easy alignment thanks to the keys on the BMT tool holder
- Very simple & reliable live tool clutch
- Very accurate positioning of tool holders thanks to BMT system
- Easy maintenance

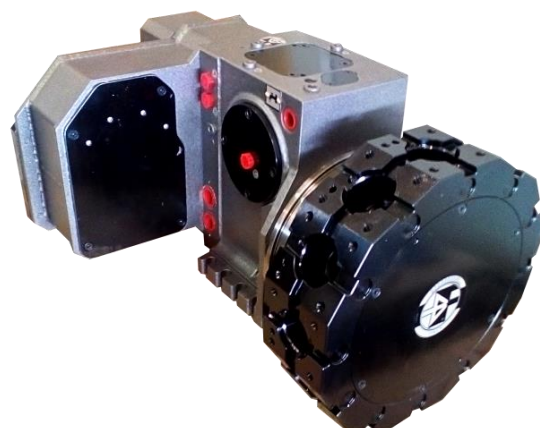

Size		TBMR160	TBMR200	TBMR250	TBMR320
BMT		45	55-65	65-75	75-85
Max Speed	rpm	6000	5000	5000	3000
Max Motor Torque	Nm	20	50	55	100
Max Power	Kw	6	9	10	15
Ratio		1:1	1:1	1:1	1:1
Locking System	PN	•	•	•	
	HYD	•	•	•	•

This data sheet show the characteristic of the Driven Tool Unit, for the turret see the TB's data sheet.

ECO-LINE: TBH Servo Turret

A new **ECO LINE** of Servo Turrets has been designed, in order to match the global competition. They use a **fully hydraulic locking system** and rotate thanks to a **BRUSHLESS SERVO MOTOR** controlled by a **SERVO DRIVE**.

TBH turrets have a really extremely **simple design**, really high performances and request a minimum maintenance.

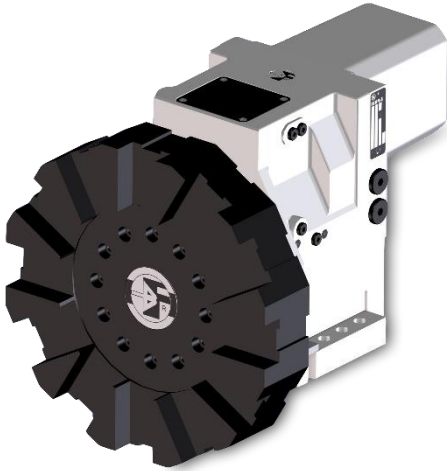

Size		TBH160	TBH200	TBH250
N° of divisions		8 - 12 - 16 - 24		
Max Moment of Inertia	Kgm ²	0,15±0,18	0,4÷8	0,4÷8
Max Tangential	Nm	1900	4000	7500
Max Overturning Torque (pressing)	Nm	2100	6000	12000
Max Overturning Torque (lifting)	Nm	1600	3500	6500
Positioning Accuracy	Deg.	±4"		
Accuracy of Repeatability	Deg.	±1,6"		
Hydraulic Locking Pressure		40 ± 3 bar		
Coolant pressure (standard)		40 Bar		
Coolant pressure (special)		70 Bar		

ECO-LINE: TBHMA (With Axial Driven Tools)

TBHMA-type turrets, **ECO Line Servo Turrets with axial driven tools**. Discs according to ISO 10889 (ex DIN 69880) norms can be used. Compact overall dimensions of the driven tool system, very high rotating tools speed, double sensor switches for the tool engagement control.

Possibility for **forced lubrication** in order to increase the **working time (100%)** and the **speed (8000rpm)**

Size		TBHMA160	TBHMA200	TBHMA250
VDI		30-40	40-50	50
Max Speed	rpm	6000	5000	5000
Max Motor Torque	Nm	20	50	55
Max Power	Kw	6	9	10
Hydraulic Locking Pressure	Bar	40		
Live Tooling System		Baruffaldi	Baruffaldi	Baruffaldi
		DIN 1809	DIN 1809	DIN 1809
		DIN 5480	DIN 5480	DIN 5480

This data sheet show the characteristic of the Driven Tool Unit, for the turret see the TBH's data sheet.

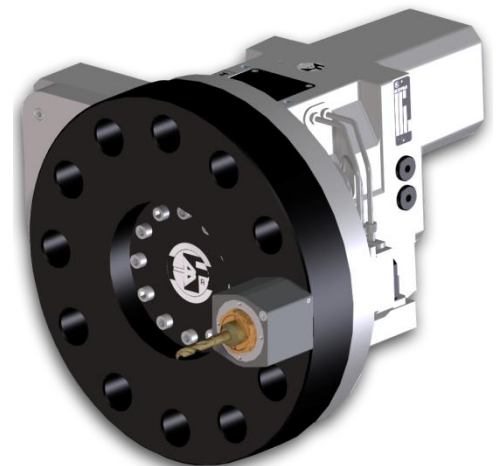

TAB Bi-Directional Servo Turret (Vertical Axis Turret)

They use a **fully hydraulic locking system** and rotate thanks to a **BRUSHLESS SERVO MOTOR** controlled by a **SERVO DRIVE**.

TAB turrets are **bi-directional, no body lifting** during the indexing rotation, really simple design, really high performances and request a minimum maintenance.

Turrets can carry 4/6 tools as per DIN 3425 norms; on demand, they can be supplied with a different number of faces.



Size		TAB 210	TAB 265	TAB 340
N° of stations		4 - 6		
Max Moment of Inertia	Kgm ²	4	9	22
Max Tangential Torque	Nm	3200	6560	13850
Max Overturning Torque (pressing)*	Nm	6600	13800	29500
Max Overturning Torque (lifting)*	Nm	2600	5000	10900
* Distance from turret axis	mm	200	250	300
Positioning Accuracy	Deg.	±4" Deg.		
Accuracy of Repeatability	Deg.	±1,6" Deg.		
Hydraulic Locking Pressure	Bar	40 Bar		

Y-AXIS Series

YAX - Y-Axis Slide Unit

The YAX unit allows displacement of tools in lathe Y-direction, in order to produce manifolds where out-of-axis operations are required, such as face millings, holes and tapping, key-slots and so on. It can be fitted on flat bed lathes as well as on slant bed lathes, where required y-axis movement is perpendicular to machine slide. The rugged meehanite cast iron column with wide sliding guideways and all other strongly designed components, together with hydraulic guideways preload system allow hard machining operations either with fixed and live tools.

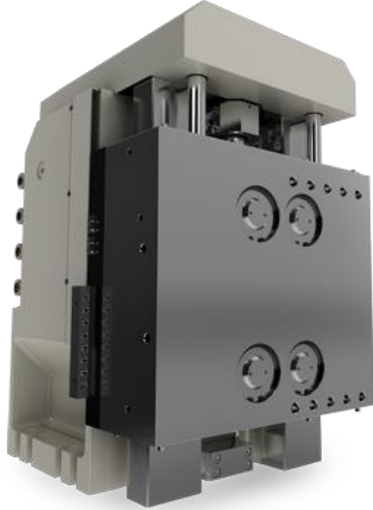

Size		YAX16	YAX25		YAX32
Turret Size		160	200	250	320
Nominal Stroke	mm	+55/-55	+70/-70	+70/-70	+100/-100
Max Feed Speed	m/min	10	10	10	10
Max Feed Force	N	12000	18000	27000	32000
Min. Motor Torque	Kw	6	10	13	25
Hydraulic Brake Force	N/bar	50	90	90	180
Max. Brake Oil Pressure	bar	100	100	100	100
Accuracy of Positioning with motor encoder	µm	≤20	≤20	≤20	≤20
Accuracy of Positioning with linear encoder	µm		≤10	≤10	≤10

Upon request, a complete unit (turret + y-axis) ready for use can be supplied

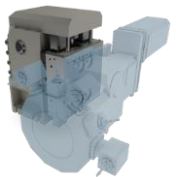

This turret has been designed for use on the Y axis of turning centers. The turret has compact overall dimensions towards the chuck, the tailstock and the slide. This solution allows use of tool holder discs with standard dimensions. Main features of these turrets are similar to TBMA and TBMR turrets.

TBYA (Turret for Y-Axis with Axial Driven Tools)

Size		TBYA160	TBYA200	TBYA250	TBYA320
VDI		30-40	40-50	50	60
Max Speed	rpm	6000	5000	5000	3000
Max Motor Torque	Nm	20	50	55	100
Max Power	Kw	6	9	10	15
Ratio		1:1	1:1	1:1	1:1
		1:1,25	1:1,315	1:1,52	1:1,45
Locking System	PN	•	•	•	
	HYD	•	•	•	•
Live Tooling System		Baruffaldi	Baruffaldi	Baruffaldi	Baruffaldi
		DIN 1809	DIN 1809	DIN 1809	-
		DIN 5480	DIN 5480	DIN 5480	-

This data sheet show the characteristic of the Driven Tool Unit, for the turret see the TB's data sheet.



TBYR VDI and BMT (Turret for Y-Axis with Radial Driven Tools)

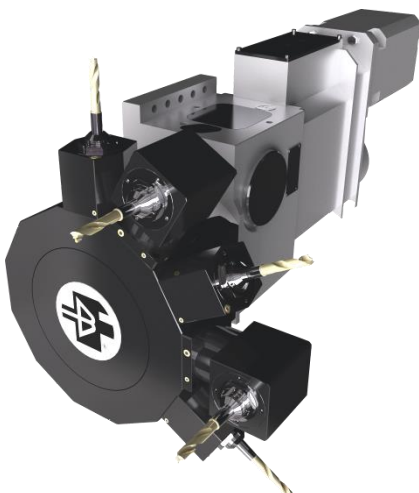

Size		TBYR160	TBYR200	TBYR250	TBYR320
VDI		30	40-50	50	60
BMT		45	55-65	65-75	75-80
Max Speed	rpm	6000	5000	5000	3000
Ratio		1:1	1:1	1:1	1:1
		1:1,23	1:1,23	1:1,23	1:1,23
Max Motor Torque	Nm	20	50	55	100
Max Power	Kw	6	9	10	15
Locking System	PN	•	•	•	
	HYD	•	•	•	•

This data sheet show the characteristic of the Driven Tool Unit, for the turret see the TB's data sheet.

ELECTROMECHANICAL TURRETS Series

TE Electromechanical Turret

These turrets have **totally electromechanical** operation both for rotation and locking. They do not require any additional hydraulic or pneumatic component. **Bi-directional rotation** and easy control by the interface PLC of the machine

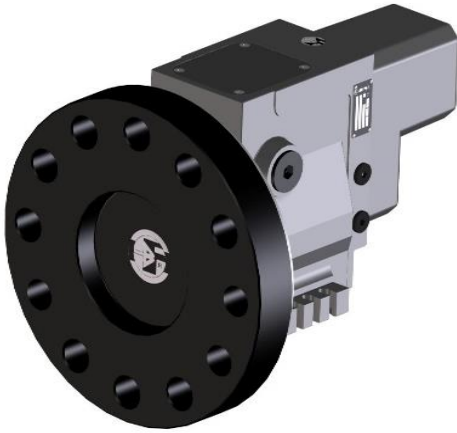

Size	TE160	TE200	TE250
N° of division	8 – 12		
Max Moment of Inertia	0,15±0,18	0,4±8	0,4±8
Max Tangential Torque	Nm 1900	4000	7500
Max Overturning Torque (pressing)	Nm 2100	6000	12000
Max Overturning Torque (lifting)	Nm 1600	3500	6500
Positioning Accuracy	Deg. ±4"		
Accuracy of Repeatability	Deg. ±1,6"		
Indexing frequency	n°/h 700	550	400
Motor Voltage	V 110– 220 – 380 – 400		

TEMA Electromechanical (With Axial Driven Tools)

Axial Power Turrets with rotating tools; standard live tool modular system applied on the TE turrets.

Fully electromechanical with compact overall dimensions of the driven tool system, very high rotating tools speed. Driven tool coupling as per DIN1809 norm and discs according to ISO 10889 (ex DIN 69880) norms can be used. Possibility for **forced lubrication** in order to increase the **working time (100%)** and the **speed (8000rpm)**.

Size	TEMA160	TEMA200	TEMA250
VDI	30-40	40-50	50
Max Speed	rpm 6000	5000	5000
Max Motor Torque	Nm 25	50	55
Max Power	Kw 6	9	10
Ratio	1:1	1:1	1:1
	1:1,25	1:1,315	1:1,52
Live Tooling System	DIN 1809	DIN 1809	DIN 1809

This table shown the technical data of the Driven Unit, for the technical data of the turret see the TE's table



TAN Electromechanical Turret (Vertical Axis Turret)

TAN series turrets is **fully electromechanical** and consist of a fixed basis and a rotating head both made of hardened and ground steel.

A single 3-phase asynchronous motor controls release, rotation, positioning and locking.

TAN series turrets can be mounted with the axis in horizontal, vertical or slanting position. Turrets can carry 4/6 tools as per DIN 3425 norms.



Size	TAN 160	TAN 210	TAN 265	TAN 340	TAN 440
N° of stations	4			4 - 6	
Max Moment of Inertia	Kgm² 1	3	8	21	55
Max weight to be carried	Kg 35	75	120	220	320
Max Tangential Torque	Nm 1100	1800	3600	12000	22000
Out of Balance in Horizontal Axis	Nm 8	35	130	200	400
Positioning Accuracy	Deg. ±6"				
Accuracy of Repetibility	Deg. ±2"				
Motor Voltage	V 110 – 220 – 380 – 400				
Brake Voltage	V 24				

TURN-MILL MULTIFUNCTION UNITS FOR LATHES OR MACHINING CENTERS

BAX-T – B Axis Unit

Baruffaldi has developed B-axis type BAX-T, thus completing its range of accessories for lathes and machining centers. Suitable for high speed machining, the BAX-T unit supports all kind of machining operations such as turning, milling, drilling, tapping – coaxial, offset and at any angle – plus three-dimensional profiling.

Big diameter Hirth teeth rings and backlash-free swiveling (built-in torque motor) allow strong machining operations with high and constant precision over time. Different tool holder systems can be supplied, such as **HSK**, **CAPTO** and others on request.

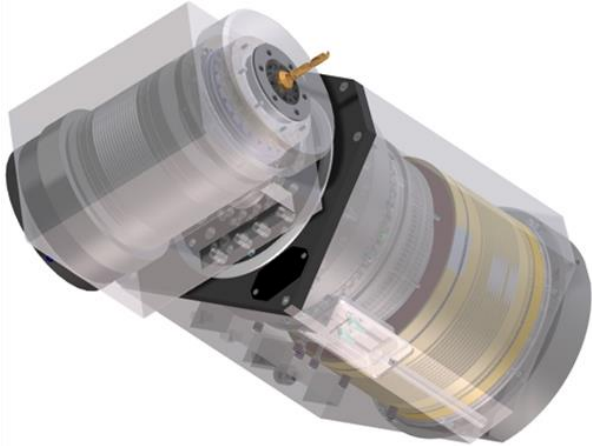

Main Characteristic:

- Swiveling controlled by a built-in torque motor
- Built-in spindle motor for tool rotation at high speed
- Foot-type fixing (others on request)
- Different toolings on request (HSK, Capto...)

MORE INFO ON DEMAND

COUPLING RINGS

Baruffaldi has been manufacturing Frontal Teeth Rings and Hirth Rings for over 50 years using them for its own products. Thanks to its long manufacturing experience and design optimization, Baruffaldi can offer custom Ring Units for all devices, designed and produced according to customer's specifications and drawings:

-FRONTAL TEETH RINGS that are used in all indexing systems, such as turning tables, revolver turrets, B-Axis units, turn-mill electrospindles and so on, in order to achieve high division precision and repeatability, together with extremely high stiffness and load capacities.

-HIRTH RINGS that are profitably used for ensuring a very stiff, strong, precise and stable Coupling in many different applications.



Hirth Profile Teeth Couplings

Thoothed 3-Ring Sets (custom design)

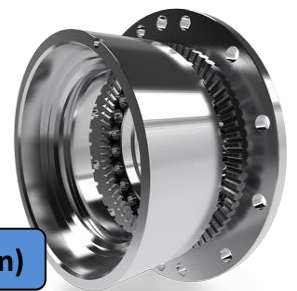

ACCESSORIES

Baruffaldi furthermore offers a wide series of Accessories for the machine tools market:

- TOOL HOLDER: Axial and Radial rotating tool holders, with shanks according to ISO 10889 (DIN69880) or BMT
- TOOL DISC: Different size and many kinds are available

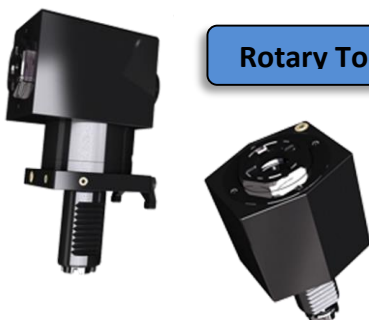

Rotary Tool Holders

Tool Holder Discs



2-Speed Planetary Gearboxes

CE Series – 2 Speed Gearboxes

Baruffaldi can supply a wide range of 2-speed planetary gearboxes, in order to meet increasing demands coming from the market. 2-speed gearboxes are commonly used on machine tools main spindles together with variable speed motors, aiming to extend the constant power field offered by the motor and to increase torque at low speeds. By using Baruffaldi two speed gearboxes, production flexibility of the machine is increased without affecting precision: high torque is available for hard materials machining and high speed for soft materials.

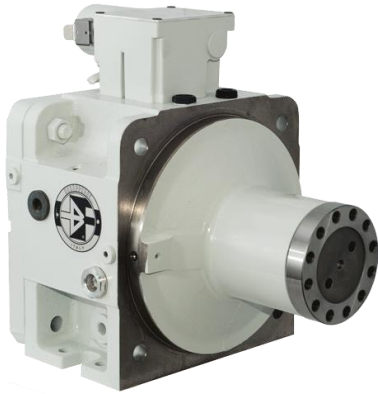

More than 25 Years of experience with 2-Speed Gearboxes

8 Gearboxes sizes

Output Torque up to 3200Nm

Input Speed up to 10.000rpm

Different Output Shafts

Suitable for any kind of motor

Size		CE11		CE12		CE13			CE14			CE15			CE16		CE18		CE20				
Available Ratios	I=	4	4.48	4	5	4	4.4	4.9	4	5	5.5	4	5	5.5	4	5	4	5	4				
Nominal Power	Kw	19		22		40			50			54			60		63		84				
Nominal Input Torque (S1)	Nm	120		140		260			325	280	280	400	340	340	450		600		800				
Nominal Output Torque	Nm	480	540	560	700	1040	1144	1280	1300	1400	1540	1600	1700	1870	1800	2250	2400	3000	3200				
Max input Speed	rpm	8000		8000		7000			6300			6300			5000		5000		5000				
Mass	1:1	Kgcm ²		134		189		310			624			680			1587		1630	2066			
Moment of Inertia	1:i	output	input	Kgcm ²		400	400	378	550	1136	1355	1570	1480	2075	2450	1530	2880	2660	6208	9400	6256	9450	6896
Max Angular Backlash (standard)																							
Max Angular Backlash (reduced)	arcmin																						
Max Radial Backlash	mm																						
Max Axial Backlash	mm																						
Max Vibration value	mm/s																						
Splash Lubrication (opp max 4500rpm)		•		•		•			•			•			•				•				
Forced Lubrication		•		•		•			•			•			•				•			•	

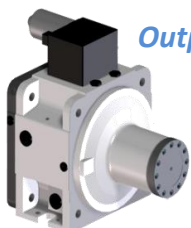

Output Flange type

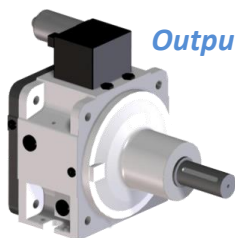

Output Shaft type

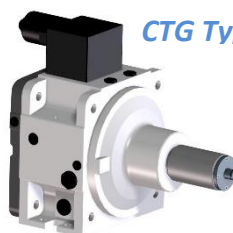

CTG Type (Coolant Through Gearbox)



7

BARUFFALDI SPA – MACHINE TOOL DIVISION

Via Cassino D'Alberi n°16, 20067 Tribiano (Milan) Italy - Tel. +39 02906090 Email sales.mtc@baruffaldi.it



www.Baruffaldi.it



facebook.com/BaruffaldiSpa



twitter.com/BaruffaldiSpa



youtube.com/BaruffaldiSpa

DMLieferant Ten.: +7 (495) 990-25-55 www.dmliefer.ru